

**450A 1200V Half bridge module**

**1 Description**

These Insulated Gate Bipolar Transistor used advanced trench and Fieldstop technology design, provided excellent  $V_{CEsat}$  and switching speed ,low gate charge. Which accords with the RoHS standard.

**2 Features**

- FS Trench Technology, Positive temperature coefficient
- Low saturation voltage:  $V_{CE(sat)}$ , typ = 1.75V @  $I_c = 450A$  and  $T_j = 25^\circ C$
- Extremely enhanced avalanche capability

**3 Applications**

- Welding
- UPS
- Three-level Inverter
- AC and DC servo drive amplifier



Type	$V_{CE}$	$I_c$	$V_{CEsat}, T_j=25^\circ C$	$T_{jop}$	Package
DGB450H120L2T	1200V	450A ( $T_j=100^\circ C$ )	1.75V (Typ)	175°C	62MM

**4 Equivalent Circuit Schematic**

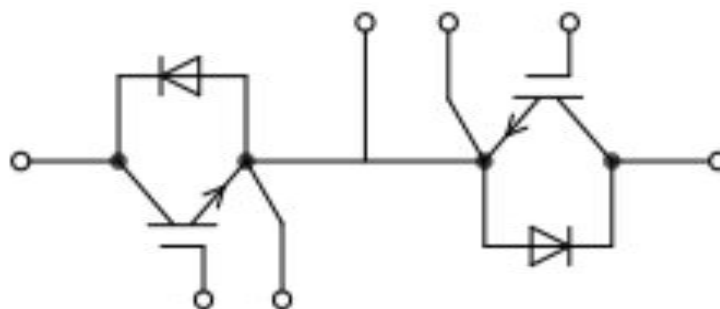

## 5 Electrical Characteristics

### 5.1 Absolute Maximum Ratings (IGBT) (Tc=25°C, unless otherwise specified)

Parameter	Symbol	Value	Units
Collector-to-Emitter Voltage	$V_{CE}$	1200	V
Gate-to-Emitter Voltage	$V_{GE}$	±20	V
DC Collector current	$I_c$	450	A
Pulsed Collector Current #1	$I_{CM}$	1200	A
$T_{vj} = 175^{\circ}\text{C}$ , $V_{CC} = 800\text{V}$ , $V_{GE} = 15\text{V}$ , $V_{CEmax} = V_{CES} - L_{SCE} \cdot di/dt$ $T_P \leq 6 \text{ us}$	$I_{sc}$	1000	A

Notes: #1 Pulse duration is limited by  $T_{j,max}$

### 5.2 Absolute Maximum Ratings (Diode) (Tc=25°C, unless otherwise specified)

PARAMETER	SYMBOL	VALUE	UNIT
Peak Repetitive Reverse Voltage	$V_{RRM}$	1200	V
DC Blocking Voltage	$V_R$	1200	V
Average Rectified Forward Current	$I_{F(AV)}$	400	A
Repetitive Peak Surge Current	$I_{FRM}$	900	A
$I^2t$ -value	$I^2t$	3600	A

### 5.3 IGBT Module

Parameter	Symbol	VALUE	Units
Junction Temperature Range	$T_{jmax}$	-40~175	°C
Operating Junction Temperature	$T_{jop}$	-40~150	°C
Storage Temperature Range	$T_{stg}$	-40~120	°C
Isolation Voltage $R_{MS}, f=50\text{Hz}, t=1\text{min}$	$V_{ISO}$	4000	V

### 5.4 Thermal Characteristics (IGBT Module)

Parameter	Symbol	Rating	Units
Thermal Resistance Junction to Case	IGBT	0.105	°C/W
	Diode	0.14	

### 5.5 Module characteristics

Parameter	Symbol	Conditions	VALUE	Units
Material of module baseplate			Cu+Ni	
Internal isolation		Basic insulation	Improved Al2O3ceramic	
Mounting torque of screws to heat sink	Ms	M5	3.0-6.0	N·m
Mounting torque of screws to terminals	Mt	M6	2.5-5.0	N·m
Comperative tracking index	$C_{TI}$		>175	
Stray inductance module	$L_{SCE}$		25	nH

**5.5 Electrical Characteristics (IGBT) (Tc=25°C, unless otherwise specified)**

Parameter	Symbol	Conditions	Value			Units
			Min	Typ	Max	
<b>Static Characteristics</b>						
Collector-to-Emitter Breakdown Voltage	$V_{(BR)CES}$	$I_C=250\mu A, V_{GE}=0V, T_j=25^\circ C$	1200	--	--	V
Collector-to-Emitter Leakage Current	$I_{CES}$	$V_{CE}=1200V, V_{GE}=0V, T_j=25^\circ C$	--	--	100	$\mu A$
		$V_{CE}=1200V, V_{GE}=0V, T_j=150^\circ C$	--	--	5.0	mA
Gate-to-Emitter Leakage	$I_{GES}$	$V_{GE}=\pm 20V, V_{CE}=0V, T_j=25^\circ C$	--	--	$\pm 100$	nA
Gate Threshold Voltage	$V_{GE(th)}$	$V_{CE}=V_{GE}, I_C=6mA$	5.0	5.6	6.0	V
Collector-emitter saturation voltage	$V_{CEsat}$	$V_{GE}=15V, I_C=450A, T_j=25^\circ C$	--	1.75	--	V
		$V_{GE}=15V, I_C=450A, T_j=150^\circ C$	--	2.20	--	V
<b>Dynamic Characteristics</b>						
Input Capacitance	$C_{iss}$	$V_{CE}=25V, V_{GE}=0V, f=100kHz, T_a=25^\circ C$	--	72	--	nF
Output Capacitance	$C_{oss}$		--	3.8	--	
Reverse Transfer Capacitance	$C_{rss}$		--	0.42	--	
<b>IGBT Characteristics</b>						
Turn-on delay time	$t_{d(on)}$	$V_{CE}=600V, I_C=450A, R_g=5.1\Omega, V_{GE}=15V, \text{感性负载}, T_j=25^\circ C$	--	267.2	--	nS
Rise time	$t_r$		--	76	--	nS
Turn-off delay time	$t_{d(off)}$		--	690	--	nS
Fall time	$t_f$		--	272	--	nS
Turn-on energy	$E_{on}$		--	20.7	--	mJ
Turn-off energy	$E_{off}$		--	53.5	--	mJ
Total switching energy	$E_{ts}$		--	74.2	--	mJ
Turn-on delay time	$t_{d(on)}$	$V_{CE}=600V, I_C=450A, R_g=5.1\Omega, V_{GE}=15V, \text{感性负载}, T_j=150^\circ C$	--	240.8	--	nS
Rise time	$t_r$		--	99.2	--	nS
Turn-off delay time	$t_{d(off)}$		--	749.5	--	nS
Fall time	$t_f$		--	447.2	--	nS
Turn-on energy	$E_{on}$		--	38.9	--	mJ
Turn-off energy	$E_{off}$		--	70.3	--	mJ
Total switching energy	$E_{ts}$		--	109.2	--	mJ
Gate charge	$Q_g$	$V_{CE}=600V, V_{GE}=-15V \text{ to } 15V$	--	7.1	--	$\mu C$

**5.6 Electrical Characteristics (Diode) (Tc=25°C, unless otherwise specified)**

Parameter	Symbol	Conditions	Value			Units
			Min	Typ	Max	
Diode forward voltage	$V_F$	$I_F=450A, T_j=25^\circ C$	--	1.75	--	V
		$I_F=450A, T_j=150^\circ C$	--	1.8	--	V
Diode reverse recovery time	$t_{rr}$	$T_{vj}=25^\circ C, V_{CC}=600V, I_C=450A, V_{GE}=-15/15V, R_{G(on)}=5.1\Omega,$	--	560	--	ns
Diode peak reverse recovery current	$I_{rrm}$		--	133	--	A
Diode reverse recovery charge	$Q_{rr}$		--	33	--	$\mu C$
Reverse recovery energy	$E_{rec}$		--	10.6	--	mJ
Diode reverse recovery time	$t_{rr}$	$T_{vj}=150^\circ C, V_{CC}=600V, I_C=450A, V_{GE}=-15/15V, R_{G(on)}=5.1\Omega,$	--	1000	--	ns
Diode peak reverse recovery current	$I_{rrm}$		--	173	--	A
Diode reverse recovery charge	$Q_{rr}$		--	96	--	$\mu C$
Reverse recovery energy	$E_{rec}$		--	30.9	--	mJ

6 Typical Characteristic Curves

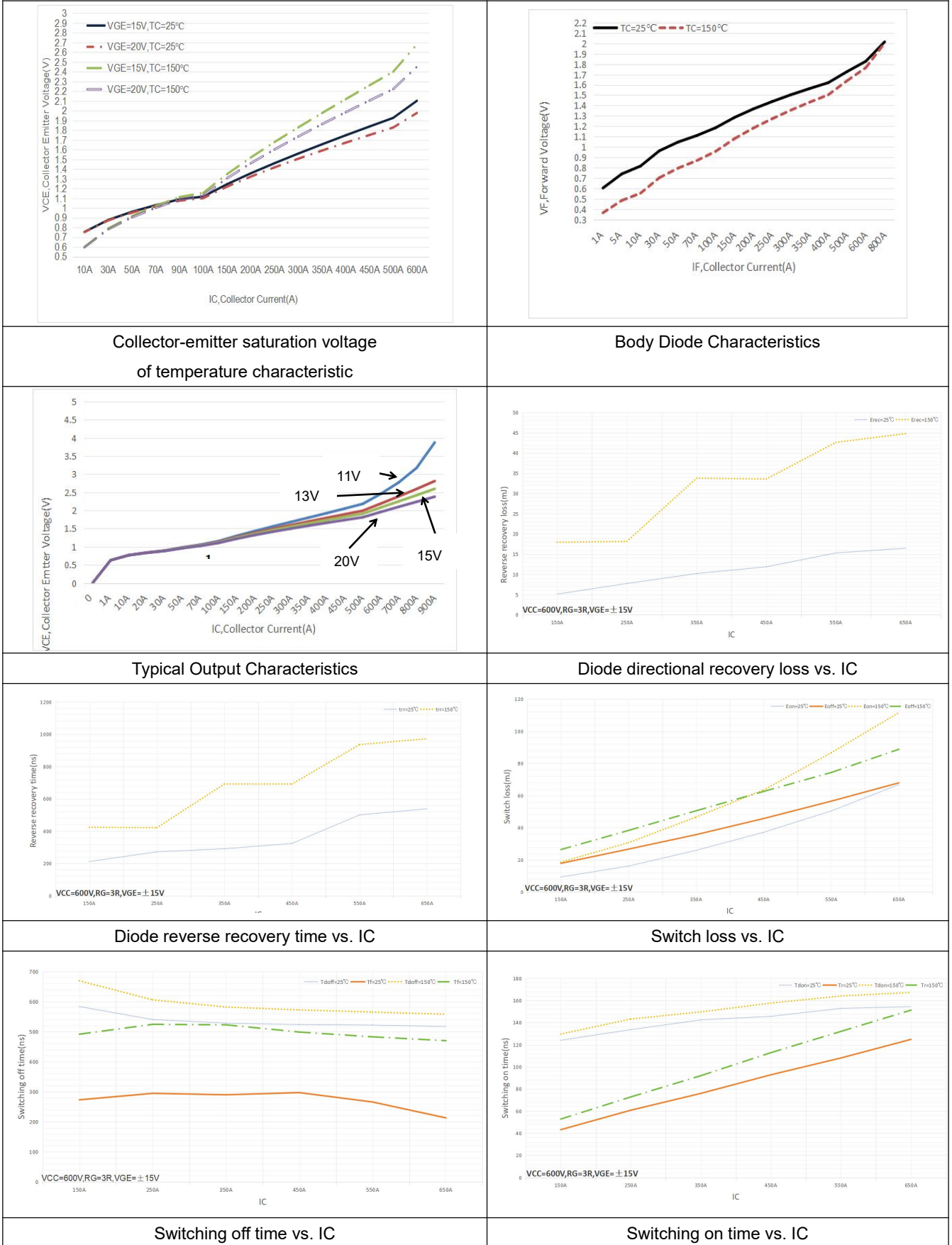

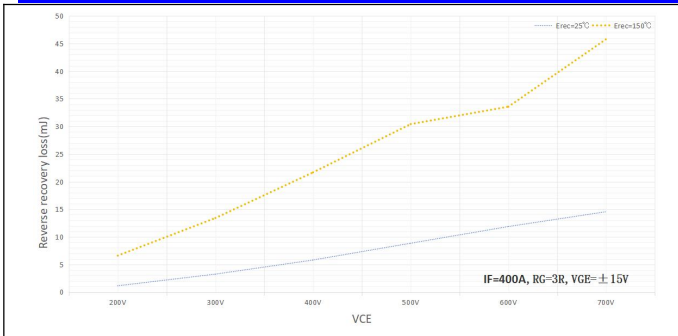

Diode directional recovery loss vs. VCE

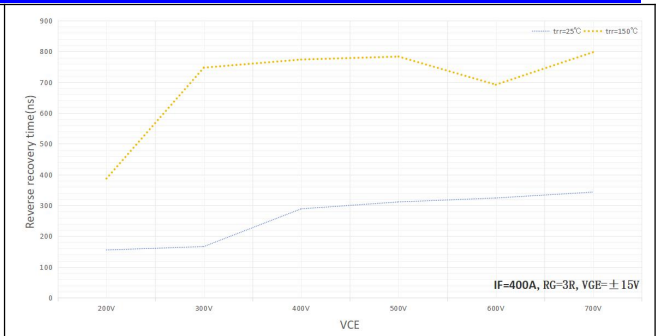

Diode reverse recovery time vs. VCE

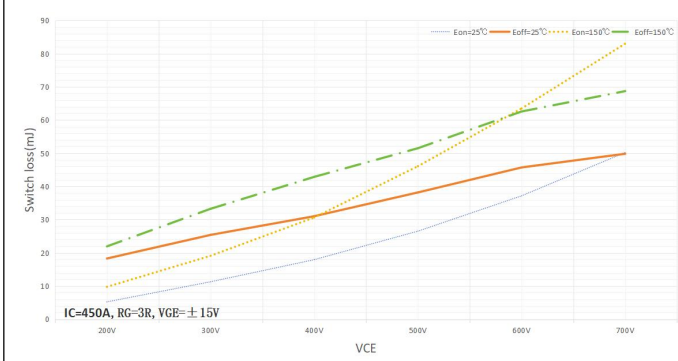

Switch loss vs. VCE

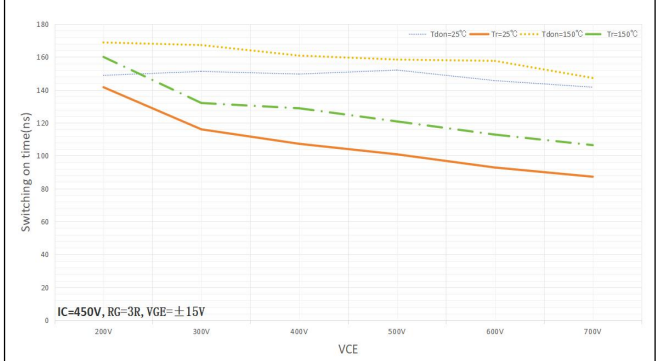

Switching on time vs. VCE



Switching off time vs. VCE

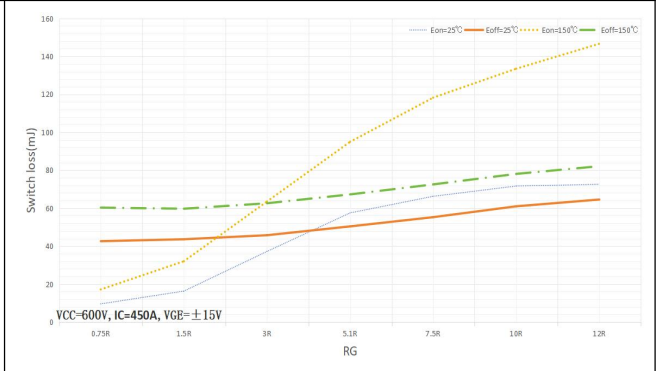

Switch loss vs. RG

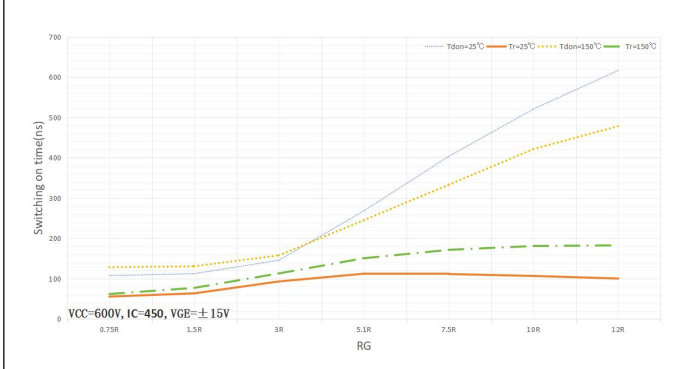

Switching on time vs. RG

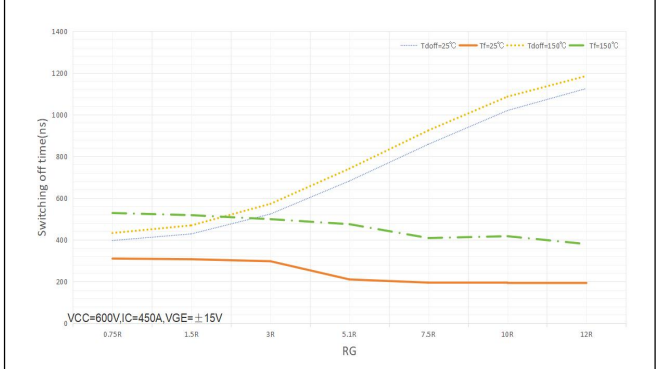

Switching off time vs. RG

**7 Dimensions**

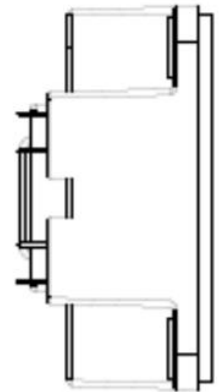
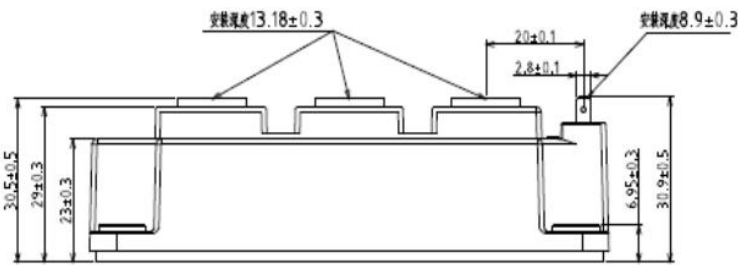
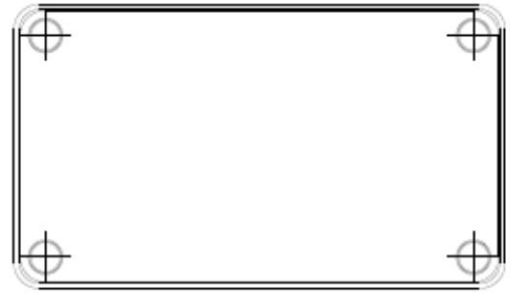
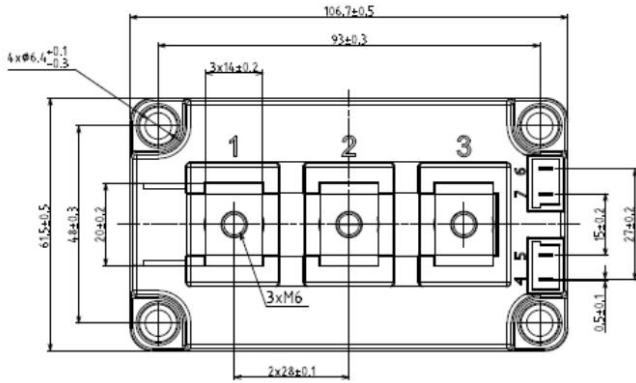

**7.1 Circuit Schematic**

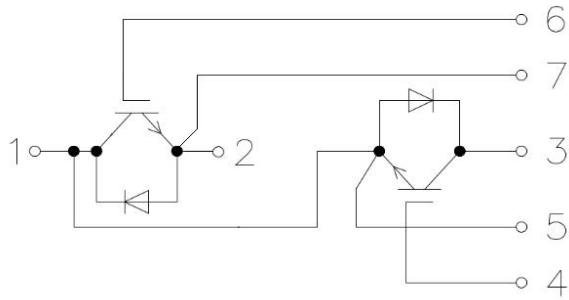

## 8 Attentions

- Jiangsu Donghai Semiconductor Technology CO.,LTD. reserves the right to change the specification without prior notice! The customer should obtain the latest version of the information before making the order and verify that the information is complete and up to date.
- It is the responsibility of the purchaser for any failure or failure of any semiconductor product under certain conditions. It is the responsibility of the purchaser to comply with safety standards and to take safety measures in the system design and machine manufacturing of Donghai products in order to avoid potential risk of failure. Injury or property damage.
- Product promotion is endless, our company will be dedicated to provide customers with better products.

## 8 Appendix

Revision history:

Date	REV.	Description	Page
2023.6.27	1.0	Original	
2024.3.30	1.1	Optimization Typical Characteristic Curves	4, 5Page