

25A 1700V SiC Schottky Barrier Diode

1 Description

SiC Series products family offers state of the art performance. It is designed for high frequency applications where high efficiency and high reliability are required.

2 Features

- high voltage
- Zero Reverse Recovery Current
- Zero Forward Recovery Voltage
- Positive Temperature Coefficient on VF
- 175°C Operating Junction Temperature

3 Applications

- Switching Mode Power Supplies
- Power Factor Correction
- Motor drive, PV Inverter, Wind Power Station

$V_{BRM}=1700V$

$I_F (T_c \leq 135^\circ C) = 26A$

$Q_c = 82nC$

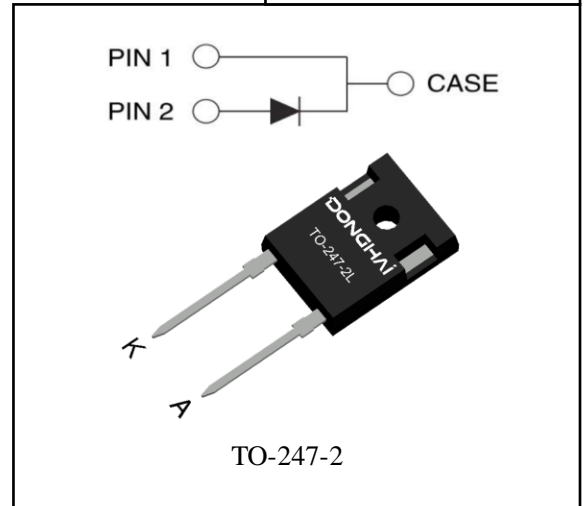

4 Electrical Characteristics

4.1 Absolute Maximum Ratings ($T_c=25^\circ C$, unless otherwise noted)

PARAMETER	SYMBOL	VALUE	UNIT
Peak Repetitive Reverse Voltage	V_{RRM}	1700	V
Working Peak Reverse Voltage	V_{RWM}	1700	V
DC Blocking Voltage	V_R	1700	V
Forward Current	I_F	26	A
<small>($T_c \leq 135^\circ C$)</small>			
Nonrepetitive Peak Surge Current($t=8.3ms$)	I_{FSM}	120	A
Power dissipation	P_{tot}	375	W
Operating Junction Temperature Range	T_j	-55~175	$^\circ C$
Storage Temperature Range	T_{stg}	-55~175	$^\circ C$
Soldering Temperature	T_{sold}	260	$^\circ C$

4.2 Thermal Characteristics

PARAMETER	SYMBOL	VALUE	UNIT
Thermal Resistance from Junction to Case	R_{thJC}	0.4	$^\circ C/W$

4.3 Electrical Characteristics (Tc=25°C, unless otherwise noted)

PARAMETER	SYMBOL	TEST CONDITION	MIN	TYP	MAX	UNIT
Maximum Instantaneous Forward Voltage	V _F	I _F = 25A	-	1.6	1.8	V
		I _F = 25A, T _J =175°C	-	2.6	4.0	V
Maximum Instantaneous Reverse	I _R	V _R = 1700V	-	2	50	uA
		V _R = 1700V, T _a =175°C	-	20	400	uA
Total capacitance	C _{tot}	V _R =0V, f=1MHz	-	1700	-	pF
		V _R =800V, f=1MHz	-	95	-	
Total capacitive Charge	Q _C	V _R =1200V, I _F =25A, di/dt=200A/us	-	82	-	nC

DEFINITIONS

V_F = Instantaneous forward voltage (pw = 300μs, D = 2%).

I_R = Instantaneous reverse current.

RθJC = Thermal resistance junction to case.

pw = pulse width.

D = duty cycle.

5 Typical characteristics diagrams

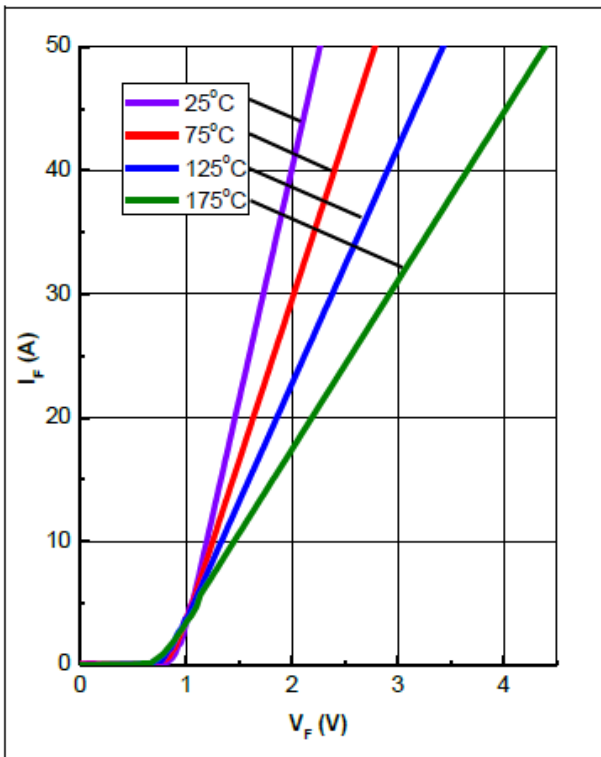

Figure 1. Forward Characteristics

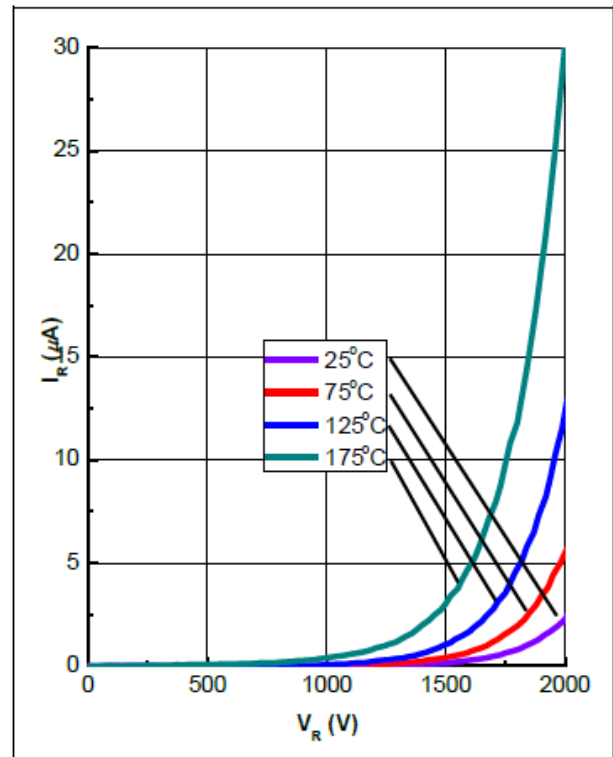

Figure 2. Reverse Characteristics

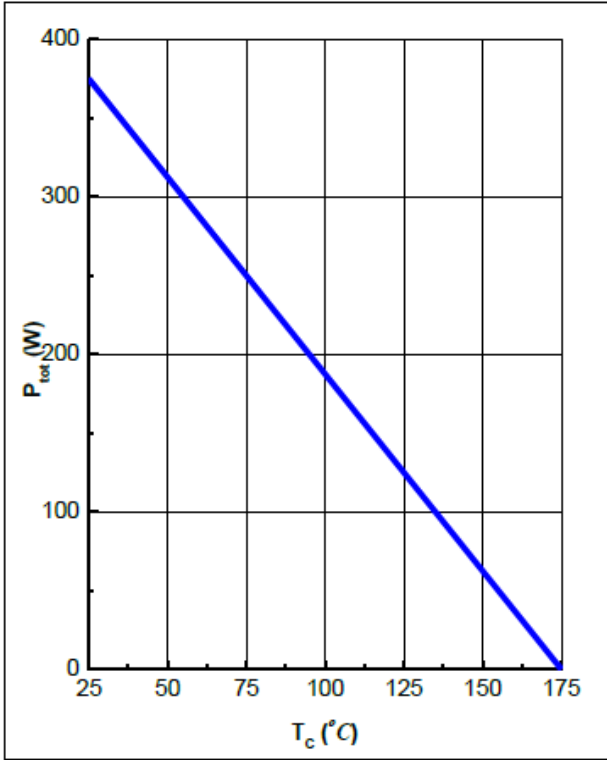

Figure 3. Power Derating

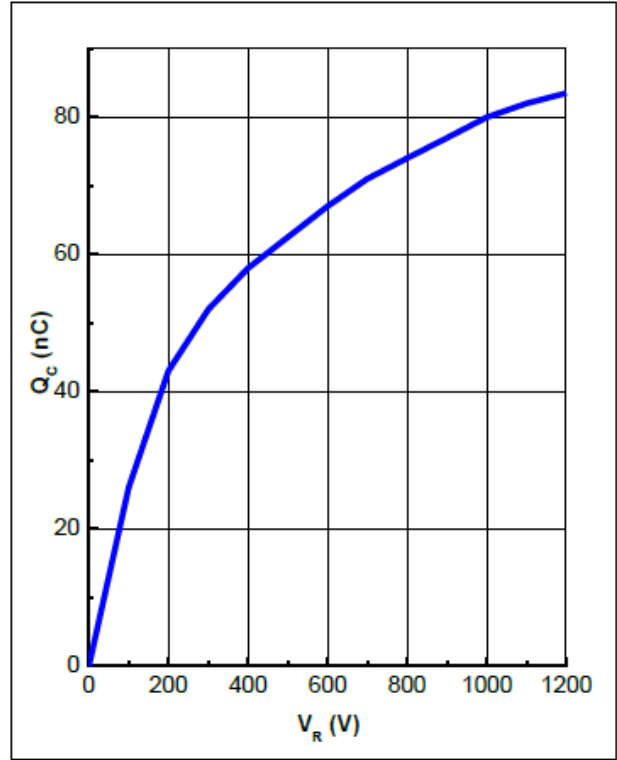

Figure 4. Total Capacitive Charge vs. Reverse Voltage

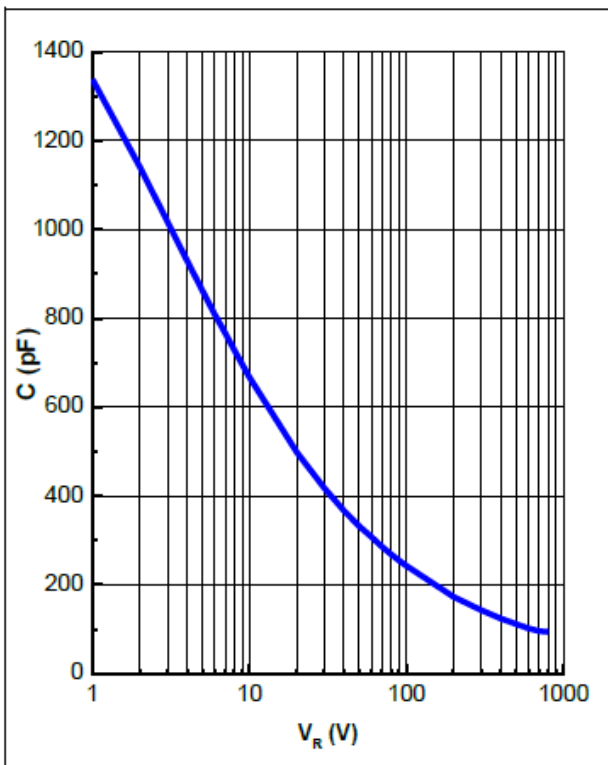

Figure 5. Total Capacitance vs. Reverse Voltage

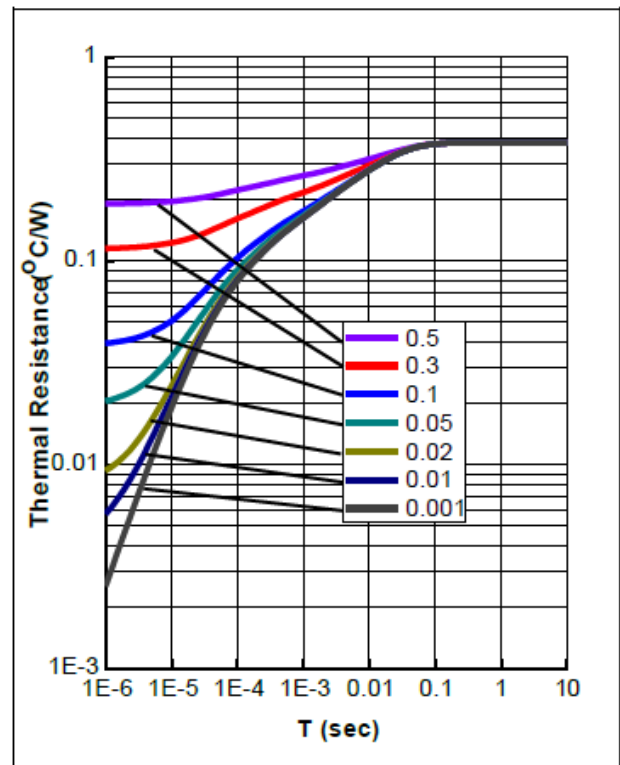

Figure 6. Transient Thermal Impedance

6 Product Specifications and Packaging Models

Product Model	Package Type	Mark Name
DCCT25D170G1	TO-247-2	DCCT25D170G1

7 Dimensions

TO-247-2 PACK OUTLINE DIMENSIONS

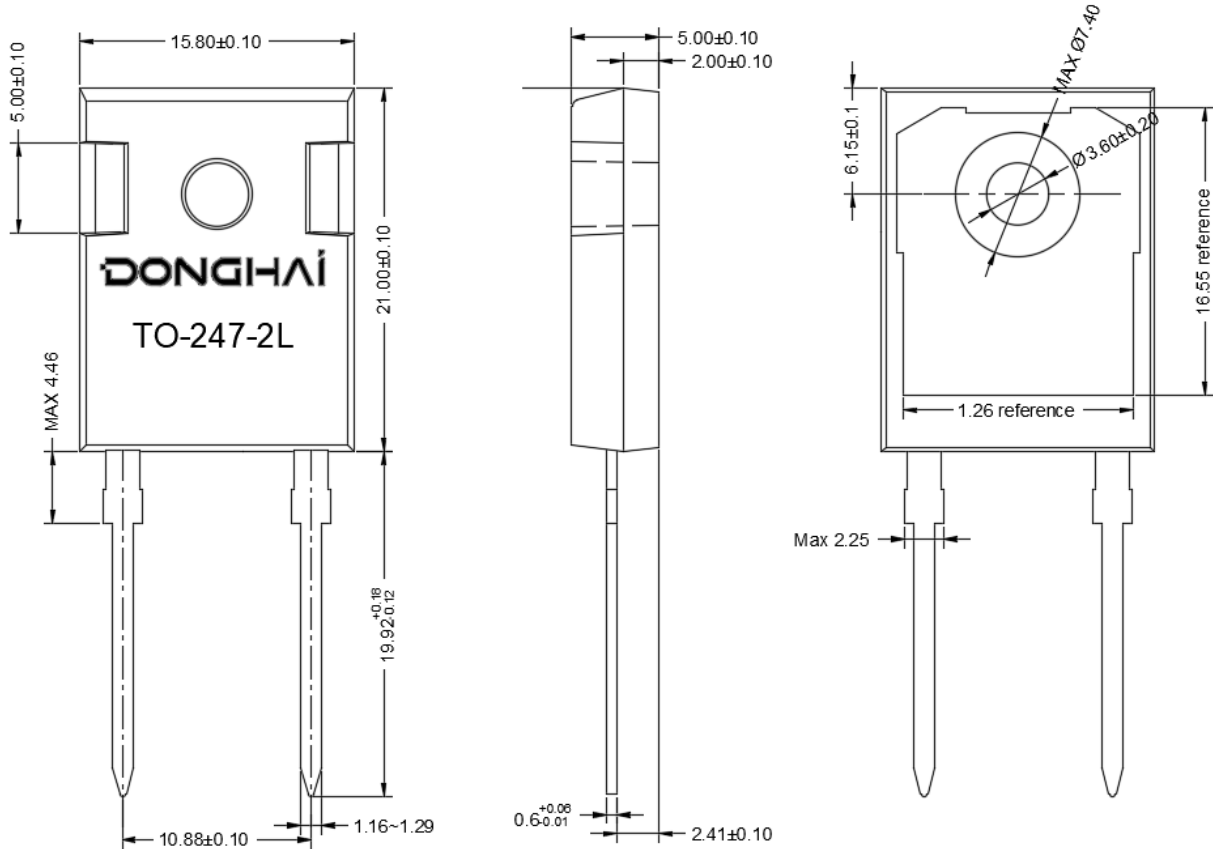

8 Attentions

- Jiangsu Donghai Semiconductor Co.,Ltd. reserves the right to change the specification without prior notice! The customer should obtain the latest version of the information before making the order and verify that the information is complete and up to date.
- It is the responsibility of the purchaser for any failure or failure of any semiconductor product under certain conditions. It is the responsibility of the purchaser to comply with safety standards and to take safety measures in the system design and machine manufacturing of Jiangsu Donghai Semiconductor Co.,Ltd. products in order to avoid potential risk of failure. Injury or property damage.
- Product promotion is endless, our company will be dedicated to provide customers with better products.

9 Appendix

Revision history:

Date	REV.	Description	Page
2022.03.01	1.0	Original	4