

13A 100V P-channel Enhancement Mode Power MOSFET

1 Description

These P-channel enhancement mode power mosfets used advanced trench technology design, provided excellent $R_{DS(on)}$ and low gate charge. Which accords with the RoHS standard.

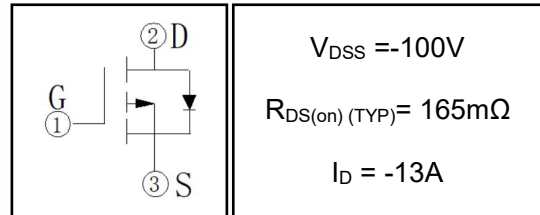

2 Features

- Low on resistance
- Low gate charge
- Fast switching
- Low reverse transfer capacitances
- 100% single pulse avalanche energy test
- 100% ΔV_{DS} test

3 Applications

- Power switching applications
- Inverter management system
- Electric tools
- Automotive electronics

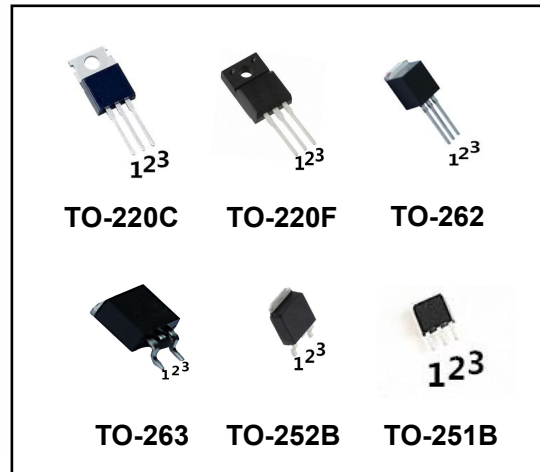

4 Electrical Characteristics

4.1 Absolute Maximum Ratings (Tc=25°C, unless otherwise noted)

Parameter	Symbol	Rating				Units	
		DH100P18	DH100P18I DH100P18E	DH100P18B DH100P18D	DH100P18F		
Drain-to-Source Voltage	V_{DSS}	-100				V	
Gate-to-Source Voltage	V_{GSS}	±20				V	
Continuous Drain Current	$T_C=25^\circ C$	-13				A	
	$T_C=100^\circ C$	-9				A	
Pulsed Drain Current ⁽¹⁾	I_{DM}	-52				A	
Single Pulse Avalanche Energy ⁽⁴⁾	E_{AS}	88				mJ	
Avalanche Current ⁽⁴⁾	I_{AS}	18.8				A	
Power Dissipation	$T_a=25^\circ C$	P_{tot}	2	2	2	2	W
	$T_C=25^\circ C$	P_{tot}	63	63	63	20	W
Isolation Voltage	V_{ISO}	/				2500	V
Junction Temperature Range	T_j	-55~175				°C	
Storage Temperature Range	T_{stg}	-55~175				°C	

4.2 Thermal Characteristics

Parameter	Symbol	Rating				Units
		DH100P18	DH100P18I DH100P18E	DH100P18B DH100P18D	DH100P18F	
Thermal Resistance, Junction to Case-sink	R_{thJC}	2.38	2.38	2.38	7.5	°C/W
Thermal Resistance, Junction to Ambient	R_{thJA}	75	75	75	75	°C/W

4.2 Electrical Characteristics (Tc=25°C, unless otherwise noted)

Parameter	Symbol	Test Condition	Value			Units
			Min	Typ	Max	
Off Characteristics						
Drain-to-Source Breakdown Voltage	BV _{DSS}	I _D =-250μA, V _{GS} =0V	-100	--	--	V
Drain-to-Source Leakage Current	I _{DSS}	V _{DS} =-100V, V _{GS} =0V, T _C =25°C	--	--	-1	μA
		V _{DS} =-100V, V _{GS} =0V, T _C =125°C	--	--	-100	μA
Gate-to-Source Leakage Current	I _{GSS}	V _{GS} =±20V, V _{DS} =0V	--	--	±100	nA
On Characteristics						
Gate Threshold Voltage	V _{GS(th)}	V _{DS} =V _{GS} , I _D =-250μA	-1	--	-3	V
Drain-to-Source on-state Resistance	R _{DS(on)}	V _{GS} =-10V, I _D =-9A	--	165	185	mΩ
Dynamic Characteristics						
Input Capacitance	C _{iss}	V _{GS} =0V, V _{DS} =-50V, f=1.0MHz	--	2132	--	pF
Output Capacitance	C _{oss}		--	60	--	
Reverse Transfer Capacitance	C _{rss}		--	46	--	
Switching Characteristics						
Turn-on Delay Time	t _{d(on)}	I _D =-9A, V _{DD} =-50V, V _{GS} =-10V, R _{GEN} =9.1Ω	--	7.7	--	nS
Turn-on Rise Time	t _r		--	27.3	--	
Turn-off Delay Time	t _{d(off)}		--	81.6	--	
Turn-off Fall Time	t _f		--	51.7	--	
Total Gate Charge	Q _g	I _D =-9A, V _{DD} =-50V, V _{GS} =-10V	--	36.2	--	nC
Gate-to-Source Charge	Q _{gs}		--	8.97	--	
Gate-to-Drain("Miller") Charge	Q _{gd}		--	4.04	--	
Drain-Source Diode Characteristics						
Diode Forward Voltage ⁽³⁾	V _{SD}	V _{GS} =0V, I _S =-9A	--	--	-1.2	V
Diode Forward Current	I _S		--	--	-13	A
Reverse Recovery Time ⁽³⁾	t _{rr}	T _J =25°C, I _F =-9, V _{ds} =-50V dI _F /dt=100A/μS, V _{GS} =0V	--	41.4	--	nS
Reverse Recovery Charge ⁽³⁾	Q _{rr}		--	37.5	--	nC

Notes:

- 1: Repetitive rating, pulse width limited by maximum junction temperature.
- 2: Surface mounted on FR4 Board, t≤10sec.
- 3: Pulse width ≤ 300μs, duty cycle ≤ 2%.
- 4: L=0.5mH, I_D=-18.8A, V_{DD}=-50V, V_{GATE}=-100V, Start T_J=25°C.

5 Typical characteristics diagrams

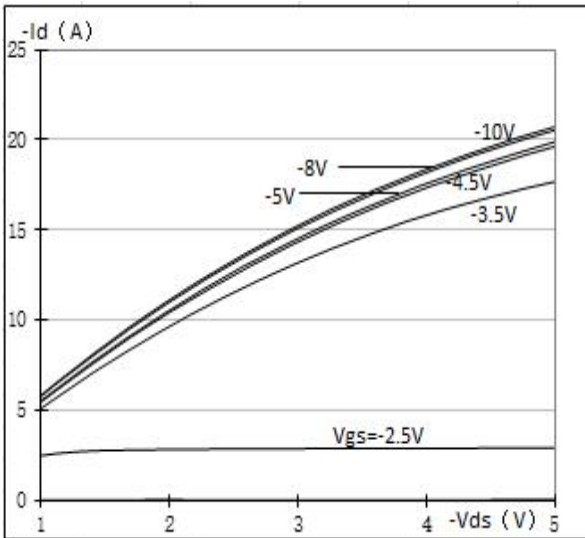

Figure 1 Output Characteristics

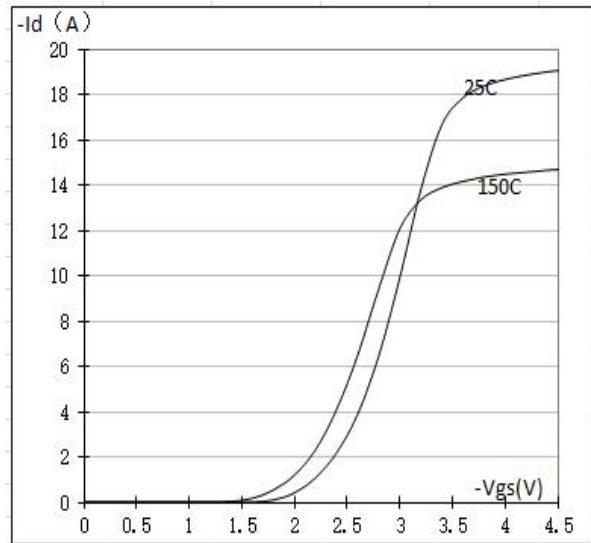

Figure 2 Transfer Characteristics

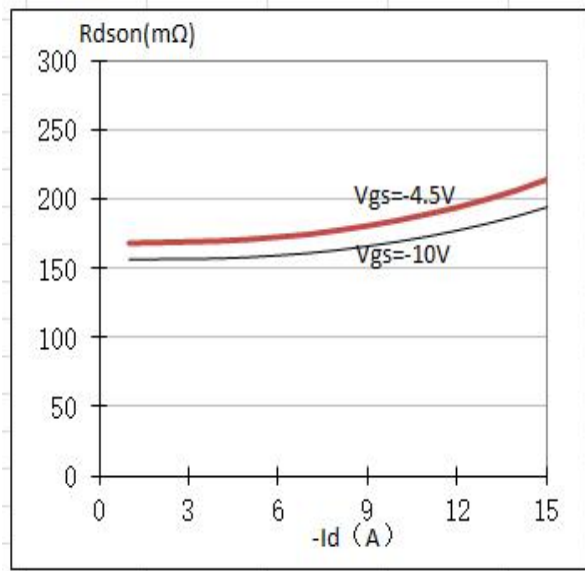

Figure 3. On-resistance vs. Drain Current

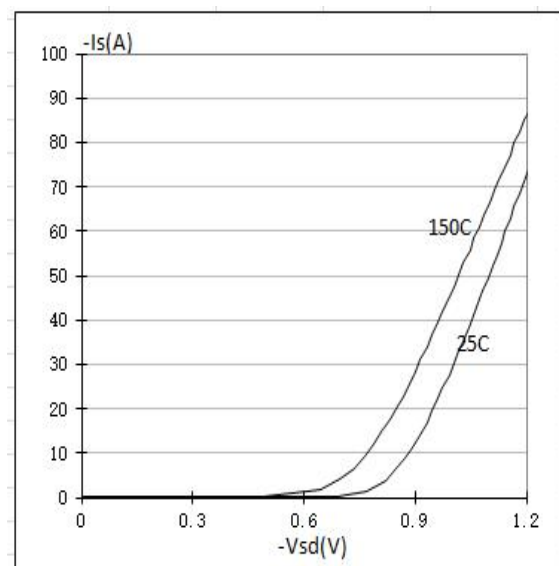

Figure 4. Source- Drain Diode Forward

5 Typical characteristics diagrams(continues)

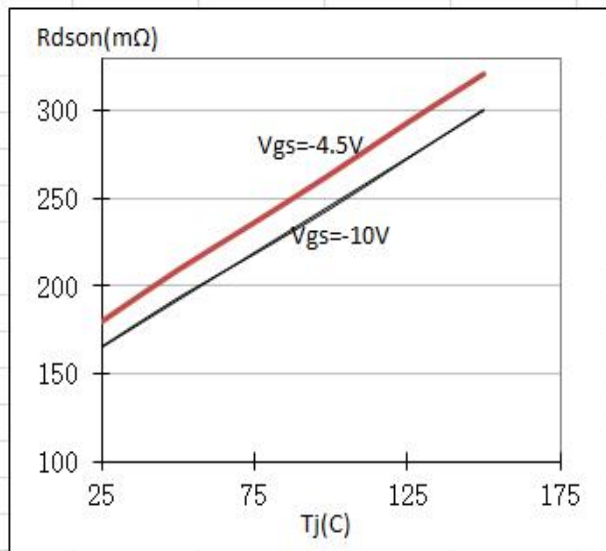

Figure 5. on Resistance vs. Junction Temperature

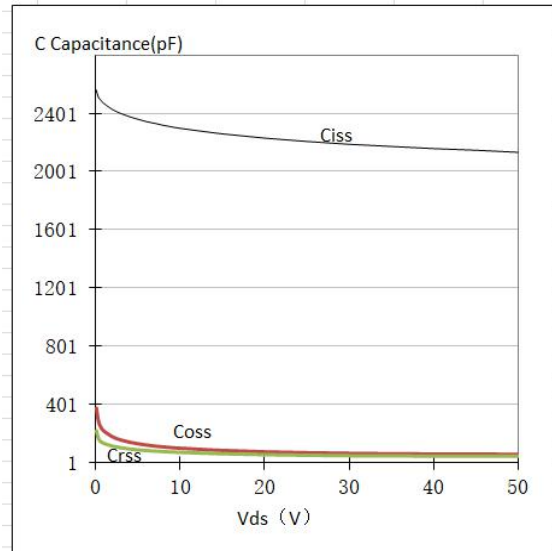

Figure 6. Capacitance vs Vds

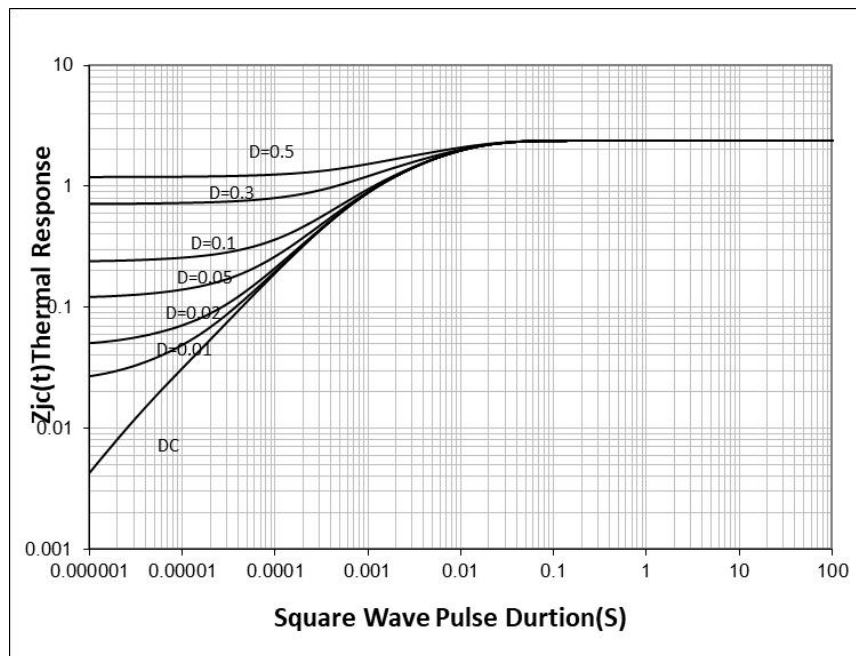

Figure 7. Normalized Maximum Transient Thermal Impedance

5 Typical characteristics diagrams(continues)

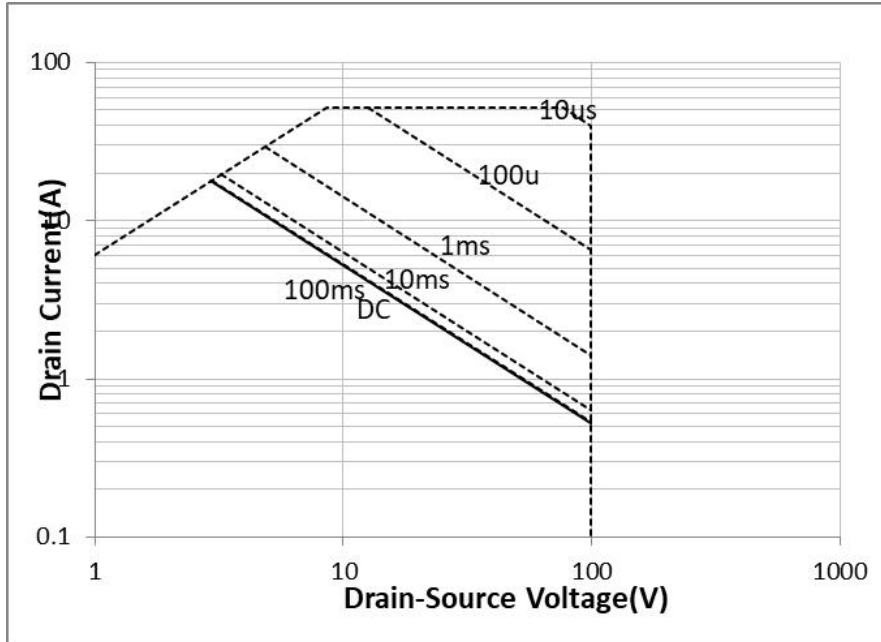
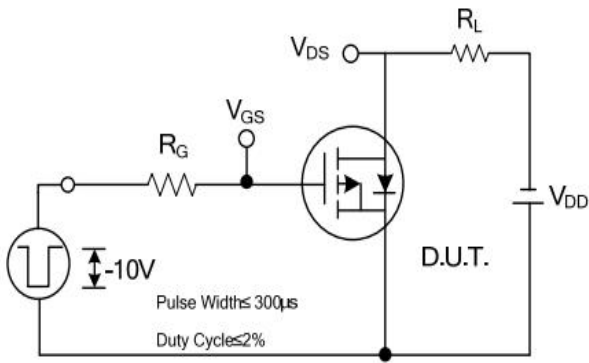
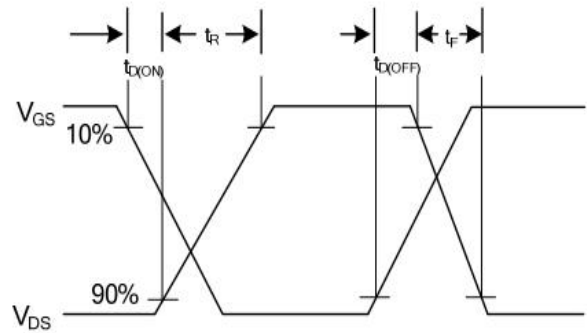

Figure 8. Safe Operation Area

6 Typical Test Circuit and Waveform



Switching Test Circuit



Switching Waveforms

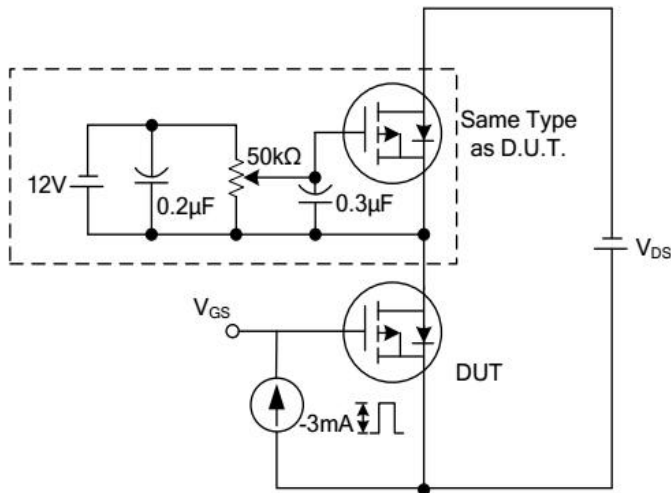

Gate Charge Test Circuit

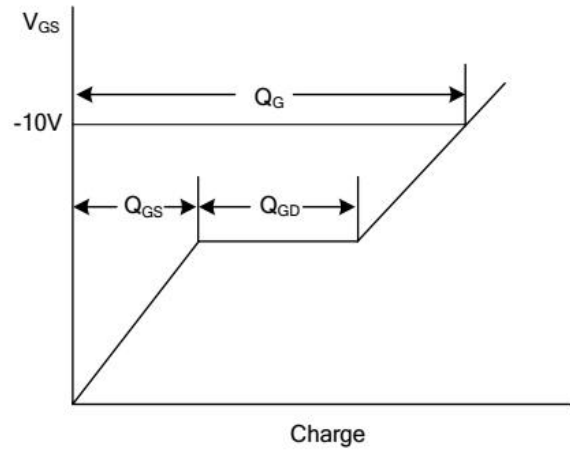

Gate Charge Waveform

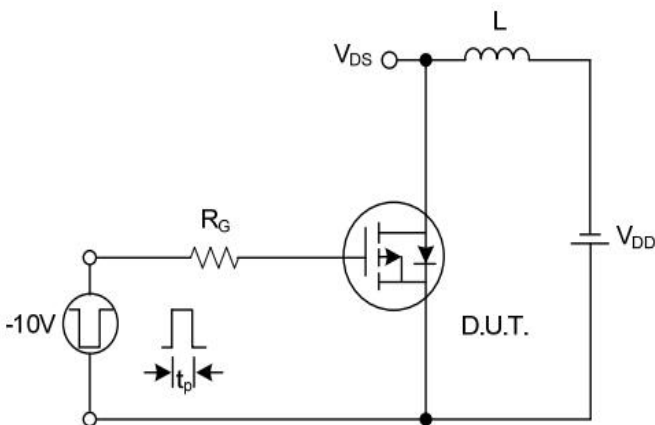

Unclamped Inductive Switching Test Circuit

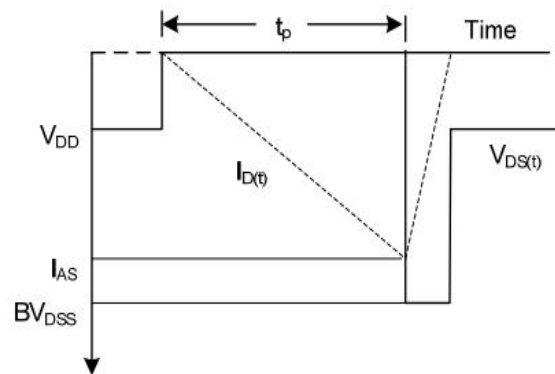

Unclamped Inductive Switching Waveforms

7 Product Names Rules

D H X X X N E X X F

LOGO Code: DH

Rated Voltage Code
With 2-3 Digital
For Example:
100 on behalf of 100V

Channel Polarity Code
N on behalf of N channel
P on behalf of P channel

Packaging Code
220F: F 220: Nothing
251: B 252: D
262: I 263: E

Rated Current Code
With 1-2 Digital
For Example:
4 on behalf of 4A
18 on behalf of 18A
08 on behalf of 0.8A

Special Function Code
E on behalf of build-in ESD
Nothing on behalf of not ESD

8 Product Specifications and Packaging Models

Product Model	Package Type	Mark Name	RoHS	Package	Quantity
DH100P18	TO-220	DH100P18	Pb-free	Tube	1000/box
DH100P18F	TO-220F	DH100P18F	Pb-free	Tube	1000/box
DH100P18B	TO-251	DH100P18B	Pb-free	Tube	3000/box
DH100P18D	TO-252	DH100P18D	Pb-free	Tape & Reel	2500/box
DH100P18I	TO-262	DH100P18I	Pb-free	Tube	1000/box
DH100P18E	TO-263	DH100P18E	Pb-free	Tape & Reel	800/box

9 Dimensions

TO-251B PACKAGE OUTLINE DIMENSIONS

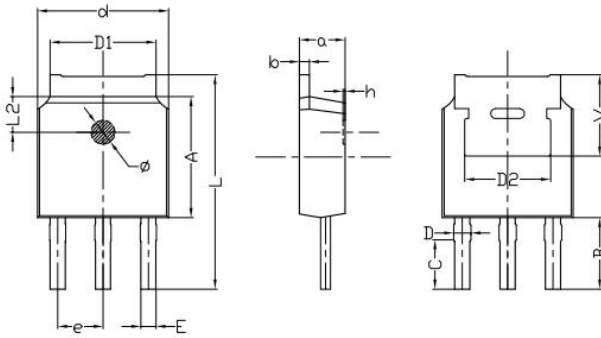

Symbol	Dimensions In Millimeters		Dimensions In Inches	
	min.	max.	min.	max.
a	2.20	2.40	0.087	0.0946
b	0.46	0.58	0.018	0.023
C	2.45	2.65	0.097	0.104
D	0.80	0.90	0.032	0.035
d	6.30	6.70	0.248	0.264
D1	5.00	5.50	0.197	0.217
D2	TYP 4.83		TYP 0.190	
A	5.80	6.20	0.228	0.244
e	2.19	2.39	0.086	0.094
L	10.40	11.00	0.4098	0.4334
B	3.50	3.70	0.1379	0.1458
L2	1.5	1.8	0.059	0.071
Φ	1.10	1.30	0.0433	0.0512
h	0.00	0.30	0.000	0.012
V	5.25	5.85	0.207	0.230
E	0.60	0.80	0.0236	0.0315

TO-252B PACKAGE OUTLINE DIMENSIONS

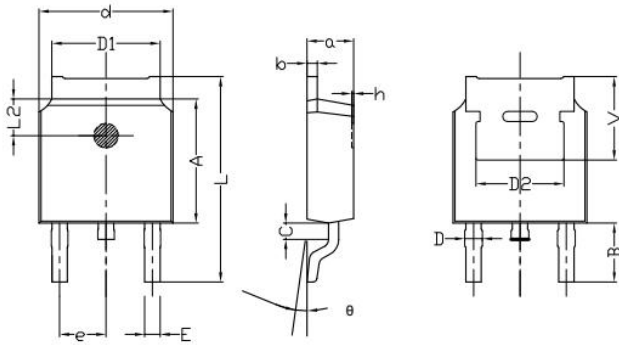

Symbol	Dimensions In Millimeters		Dimensions In Inches	
	min.	max.	min.	max.
a	2.20	2.40	0.087	0.095
b	0.46	0.58	0.018	0.023
c	0.70	0.90	0.028	0.035
D	0.80	1.00	0.032	0.039
d	6.30	6.70	0.248	0.264
D1	5.00	5.50	0.197	0.217
D2	TYP 4.83		TYP 0.190	
A	5.80	6.20	0.228	0.244
e	2.19	2.39	0.086	0.094
L	9.40	10.40	0.370	0.409
B	2.6	3.2	0.102	0.126
L2	1.5	1.8	0.059	0.071
θ	0	8	0	8
h	0	0.3	0	0.012
V	5.25	5.85	0.207	0.230
E	0.6	0.8	0.024	0.032

9 Dimensions(continues)

TO-220C PACKAGE OUTLINE DIMENSIONS

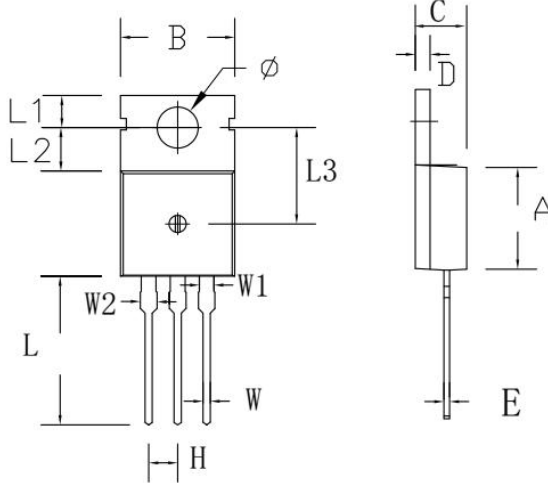

Symbol	Dimensions In Millimeters		Dimensions In Inches	
	min.	max.	min.	max.
A	8.80	9.30	0.346	0.366
B	9.70	10.30	0.382	0.406
C	4.25	4.75	0.167	0.187
D	1.20	1.45	0.047	0.057
E	0.40	0.60	0.016	0.024
H	2.54 TYP		0.100 TYP	
W	0.60	0.95	0.024	0.037
W1	1.05	1.45	0.041	0.057
W2	1.20	1.60	0.047	0.063
L	12.60	13.40	0.496	0.528
L1	2.45	2.95	0.096	0.116
L2	3.45	3.95	0.136	0.156
L3	8.15	8.65	0.321	0.341
Φ	3.50	3.90	0.138	0.154

TO-220F PACKAGE OUTLINE DIMENSIONS

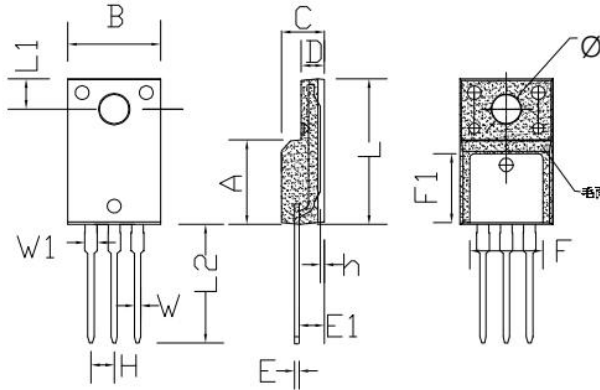

Symbol	Dimensions In Millimeters		Dimensions In Inches	
	min.	max.	min.	max.
A	8.80	9.30	0.346	0.366
B	10.00	10.50	0.394	0.413
C	4.30	4.90	0.169	0.193
D	2.30	2.70	0.091	0.106
L	15.55	16.15	0.612	0.636
h	0.40	0.60	0.016	0.024
L1	3.15	3.55	0.124	0.140
L2	12.65	13.35	0.498	0.526
W	0.70	0.90	0.028	0.035
W1	1.15	1.55	0.045	0.061
H	2.54 TYP		0.100 TYP	
E	0.48	0.53	0.019	0.021
Φ	2.90	3.40	0.114	0.134
E1	2.40	2.90	0.094	0.114
F	7.75	8.25	0.305	0.325
F1	7.35	7.85	0.289	0.309

9 Dimensions(continues)

TO-262 PACKAGE OUTLINE DIMENSIONS

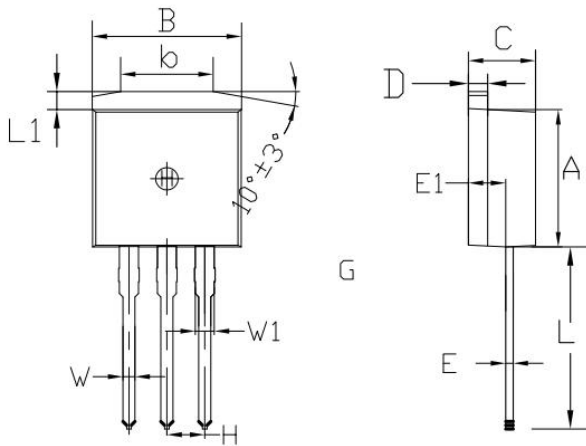

Symbol	Dimensions In Millimeters		Dimensions In Inches	
	min.	max.	min.	max.
A	8.80	9.30	0.346	0.366
B	9.70	10.30	0.382	0.406
C	4.25	4.75	0.167	0.187
D	1.20	1.45	0.047	0.057
E	0.40	0.60	0.016	0.024
L	12.25	13.75	0.482	0.541
L1	1.15	1.45	0.045	0.057
E1	2.4	2.6	0.0945	0.1024
W	0.80	0.82	0.0315	0.034
W1	1.20	1.30	0.047	0.051
H	2.54 TYP		0.200 TYP	
b	5.50	6.50	0.216	0.256

TO-263 PACKAGE OUTLINE DIMENSIONS

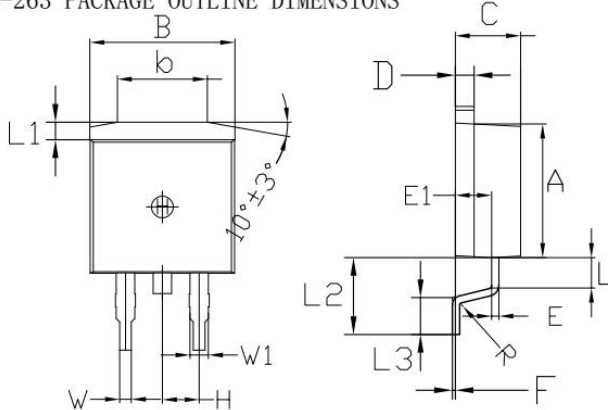

Symbol	Dimensions In Millimeters		Dimensions In Inches	
	min.	max.	min.	max.
A	8.80	9.30	0.346	0.366
B	9.70	10.30	0.382	0.406
C	4.25	4.75	0.167	0.187
D	1.20	1.45	0.047	0.057
E	0.40	0.60	0.016	0.024
L	1.90	2.30	0.075	0.091
L1	1.15	1.45	0.045	0.057
R	0.24	0.26	0.0095	0.0102
W	0.80	0.82	0.0315	0.0323
W1	1.20	1.30	0.047	0.051
H	2.54 TYP		0.200 TYP	
b	5.50	6.50	0.216	0.256
E1	2.4	2.6	0.0946	0.1024
L2	5.20	5.80	0.205	0.228
L3	2.20	3.20	0.087	0.126
F	0.03	0.23	0.0012	0.0091

10 Attentions

- Jiangsu Donghai Semiconductor Technology CO.,LTD. reserves the right to change the specification without prior notice! The customer should obtain the latest version of the information before making the order and verify that the information is complete and up to date.
- It is the responsibility of the purchaser for any failure or failure of any semiconductor product under certain conditions. It is the responsibility of the purchaser to comply with safety standards and to take safety measures in the system design and machine manufacturing of Donghai products in order to avoid potential risk of failure. Injury or property damage.
- Product promotion is endless, our company will be dedicated to provide customers with better products.

11 Appendix

Revision history:

Date	REV.	Description	Page
2017.12.20	1.0	Original	