

100A 68V N-channel Enhancement Mode Power MOSFET

1 Description

These N-channel enhancement mode power mosfets used advanced trench technology design, provided excellent $R_{DS(on)}$ and low gate charge. Which accords with the RoHS standard.

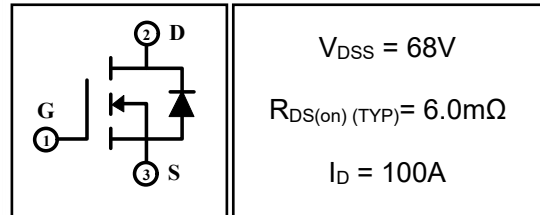

2 Features

- Low on resistance
- Low gate charge
- Fast switching
- Low reverse transfer capacitances
- 100% single pulse avalanche energy test
- 100% ΔV_{DS} test

3 Applications

- Power switching applications
- DC-DC converters
- Full bridge control

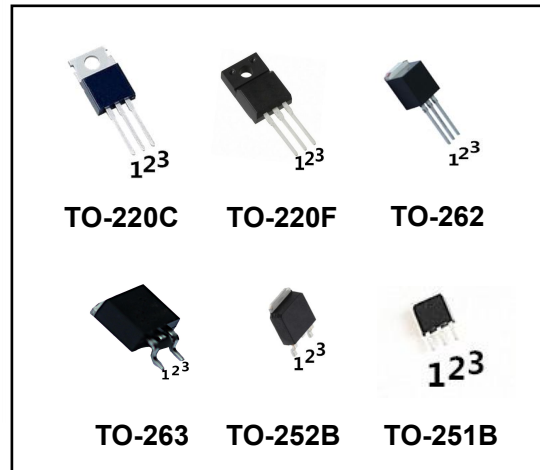

4 Electrical Characteristics

4.1 Absolute Maximum Ratings (Tc=25°C, unless otherwise noted)

Parameter	Symbol	Rating		Units	
		DH3205A/ DHI3205A/DHE3205A/ DHB3205A/DHD3205A	DHF3205 A		
Drain-to-Source Voltage	V_{DSS}	68		V	
Gate-to-Source Voltage	V_{GSS}	±20		V	
Continuous Drain Current	I_D	$T_C=25^\circ C$	100	A	
		$T_C=100^\circ C$	70	A	
Pulsed Drain Current ⁽¹⁾	I_{DM}	400		A	
Single Pulse Avalanche Energy ⁽⁴⁾	E_{AS}	600		mJ	
Avalanche Current ⁽⁴⁾	I_{AS}	49		A	
Power Dissipation	P_{tot}	$T_a=25^\circ C$	2	2	W
		$T_C=25^\circ C$	145	35	W
Isolation Voltage	V_{ISO}	/	2500	V	
Junction Temperature Range	T_j	-55 ~ 175		°C	
Storage Temperature Range	T_{stg}	-55 ~ 175		°C	

4.2 Thermal Characteristics

Parameter	Symbol	Rating		Units
		DH3205A/ DHI3205A/DHE3205A/ DHB3205A/DHD3205A	DHF3205 A	
Thermal Resistance, Junction to Case-sink	R_{thJC}	1.03	4.29	°C/W
Thermal Resistance, Junction to Ambient	R_{thJA}	75	75	°C/W

4.3 Electrical Characteristics (Tc=25°C, unless otherwise noted)

Parameter	Symbol	Test Condition	Value			Units
			Min	Typ	Max	
Off Characteristics						
Drain-to-Source Breakdown Voltage	BV _{DSS}	I _D =250μA, V _{GS} =0V	68	--	--	V
Drain-to-Source Leakage Current	I _{DSS}	V _{DS} =68V, V _{GS} =0V, T _C =25°C	--	--	1	μA
		V _{DS} =68V, V _{GS} =0V, T _C =125°C	--	--	100	μA
Gate-to-Source Leakage Current	I _{GSS}	V _{GS} =±20V, V _{DS} =0V	--	--	±100	nA
On Characteristics						
Gate Threshold Voltage	V _{GS(th)}	V _{DS} =V _{GS} , I _D =250μA	2	3	4	V
Drain-to-Source on-state Resistance	R _{DS(on)}	V _{GS} =10V, I _D =20A	--	6.0	6.5	mΩ
Dynamic Characteristics						
Input Capacitance	C _{iss}	V _{GS} =0V, V _{DS} =30V, f=1.0MHz	--	4207	--	pF
Output Capacitance	C _{oss}		--	309	--	
Reverse Transfer Capacitance	C _{rss}		--	250	--	
Gate Resisitance	R _G	V _{DD} =0V, V _{GS} =1V, F=1MHz	--	1.44	--	Ω
Switching Characteristics						
Turn-on Delay Time	t _{d(on)}	I _D =30A, V _{DD} =30V, V _{GS} =10V, R _{GEN} =6Ω	--	64.8	--	nS
Turn-on Rise Time	t _r		--	37.7	--	
Turn-off Delay Time	t _{d(off)}		--	90	--	
Turn-off Fall Time	t _f		--	26.5	--	
Total Gate Charge	Q _g	I _D =20A, V _{DD} =30V, V _{GS} =10V	--	81	--	nC
Gate-to-Source Charge	Q _{gs}		--	18.6	--	
Gate-to-Drain("Miller") Charge	Q _{gd}		--	26.4	--	
Drain-Source Diode Characteristics						
Diode Forward Voltage ⁽³⁾	V _{SD}	V _{GS} =0V, I _S =30A	--	--	1.3	V
Diode Forward Current	I _S		--	--	100	A
Reverse Recovery Time ⁽³⁾	t _{rr}	T _J =25°C, I _F =50A, di _F /dt=100A/μS, V _{GS} =0V	--	31.8	--	nS
Reverse Recovery Charge ⁽³⁾	Q _{rr}		--	33.9	--	nC

Notes:

- 1: Repetitive rating, pulse width limited by maximum junction temperature.
- 2: Surface mounted on FR4 Board, t_≤10sec.
- 3: Pulse width ≤ 300μs, duty cycle ≤ 2%.
- 4: L=0.5mH, I_D=49A, V_{DD}=50V, V_{GATE}=100V, Start T_J=25°C.

5 Typical characteristics diagrams

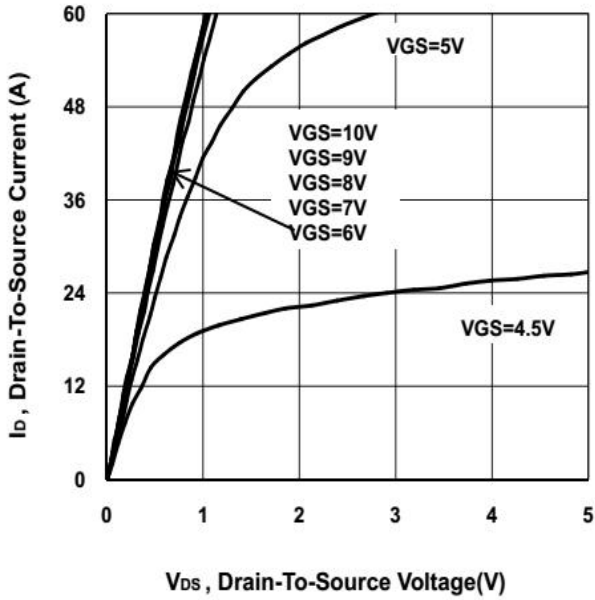

Fig 1. Output Characteristics

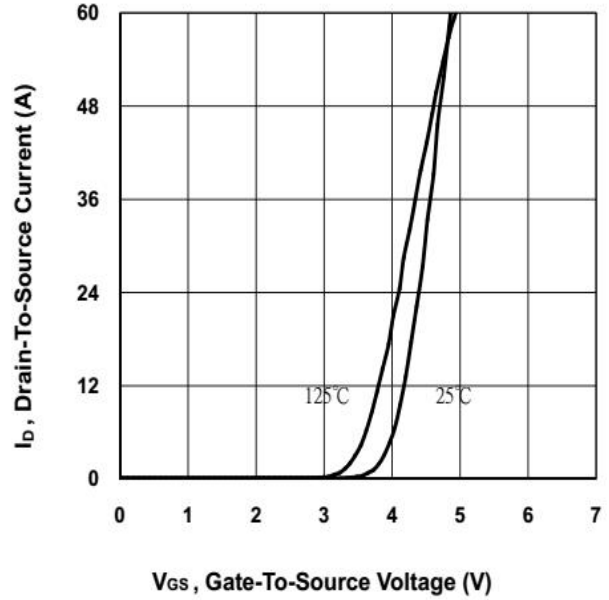

Fig 2. Transfer Characteristics

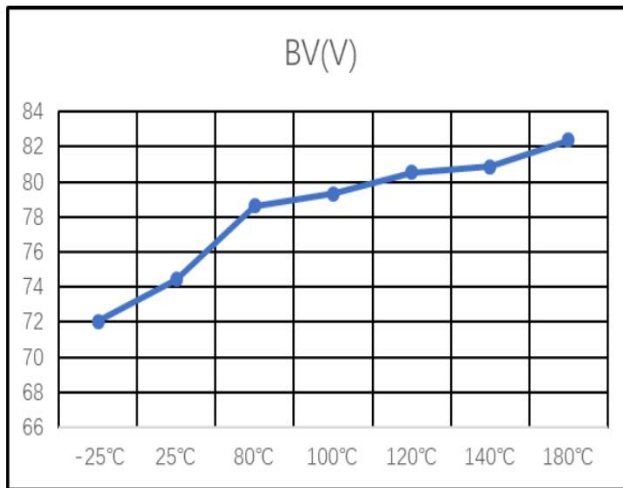

Fig 3 BVDSS vs Junction Temperature

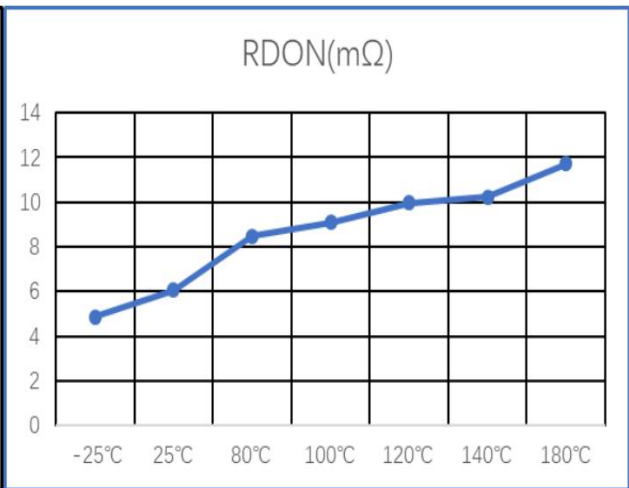

Fig 4 RDSON vs Junction Temperature

5 Typical characteristics diagrams(continues)

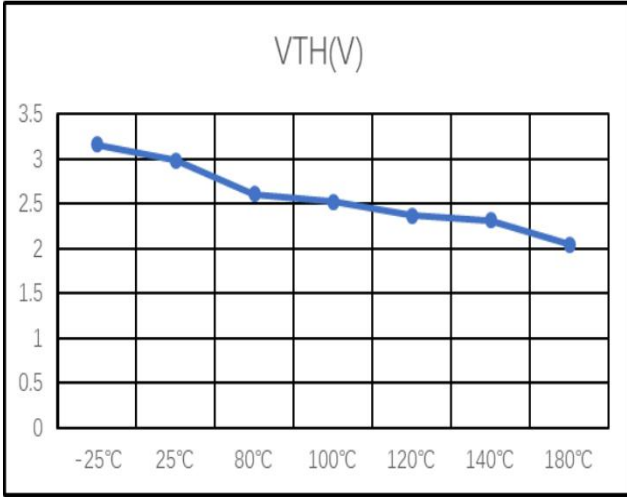

Fig 5 VTH vs Junction Temperature

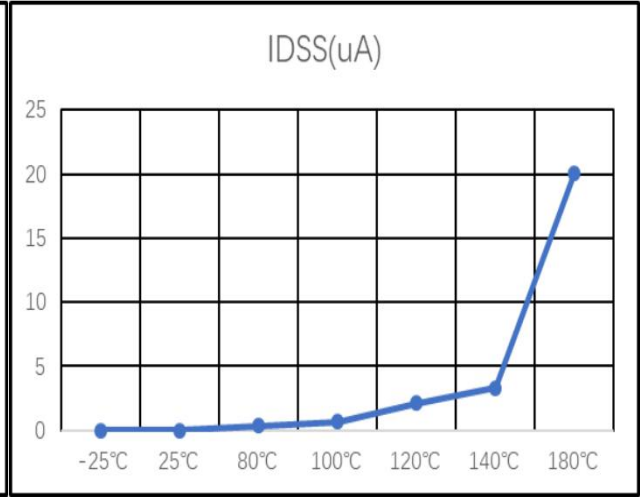

Fig 6 IDSS vs Junction Temperature

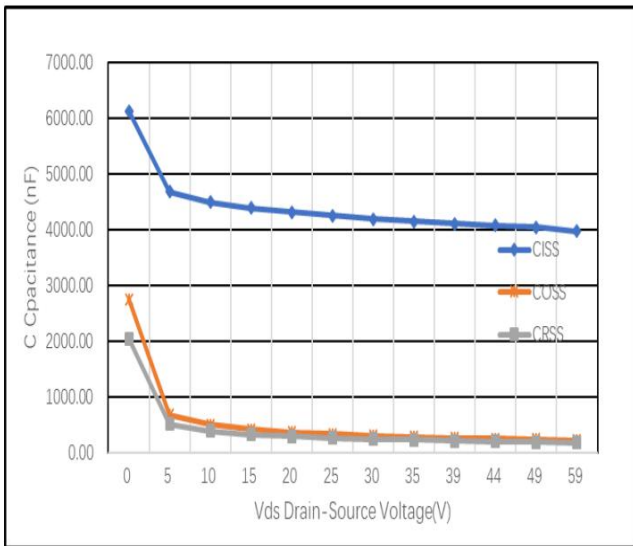

Fig 7 Capacitances vs Vds

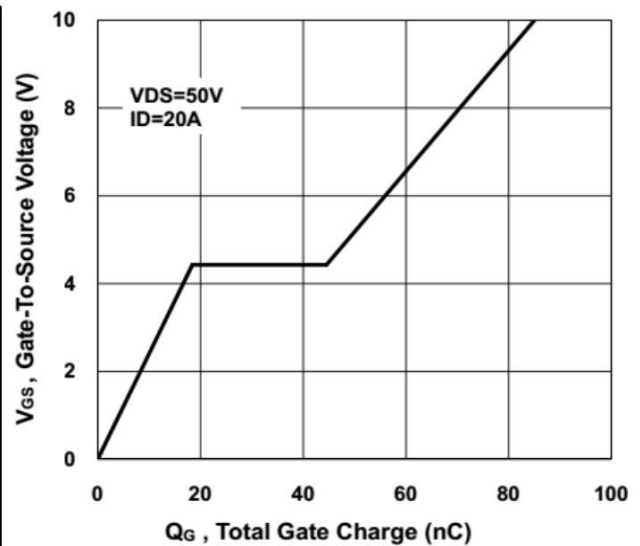

Fig 8 Gate Charge

5 Typical characteristics diagrams(continues)

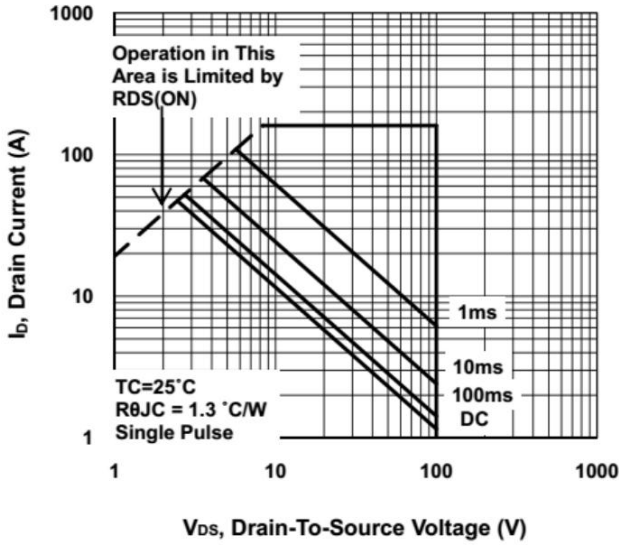

Fig 9 Safe Operation Area

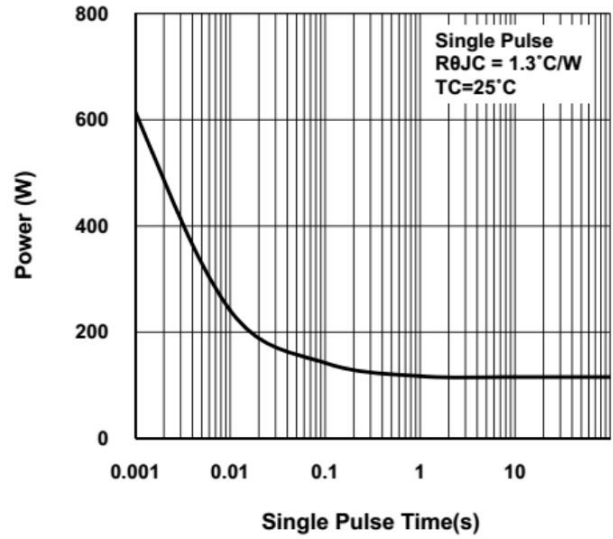

Fig 10 Single Pulse Maximum Power Dissipation

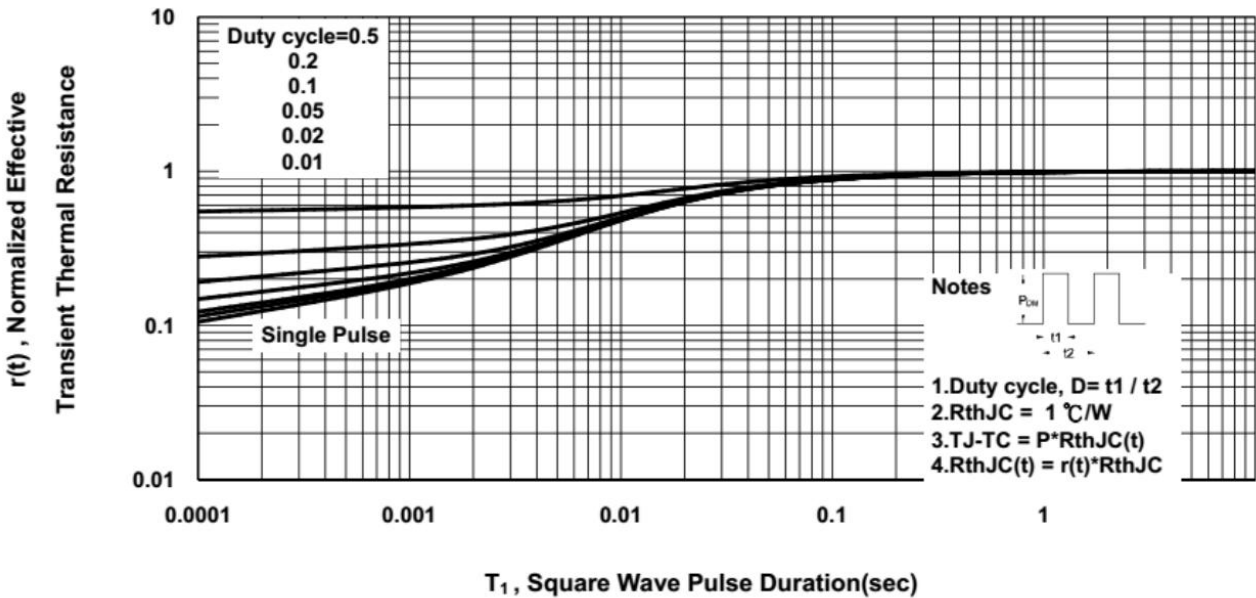
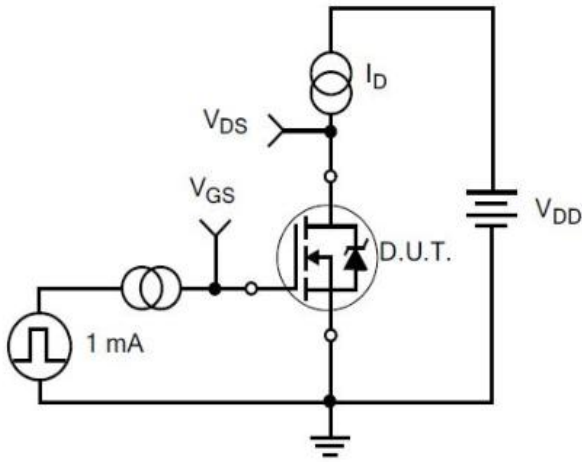
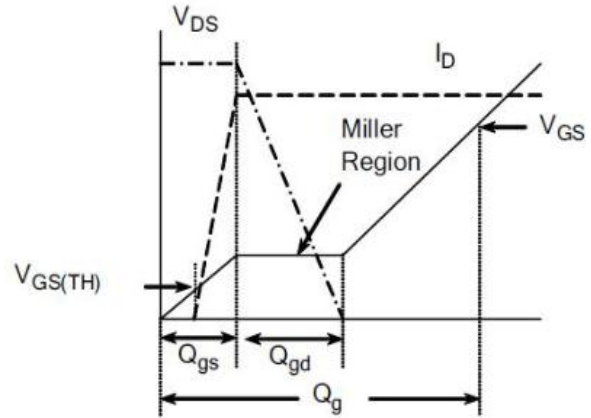

Fig 11 T1 , Transient Thermal Response Curve

6 Typical Test Circuit and Waveform



1) Gate Charge Test Circuit



2) Gate Charge Waveform

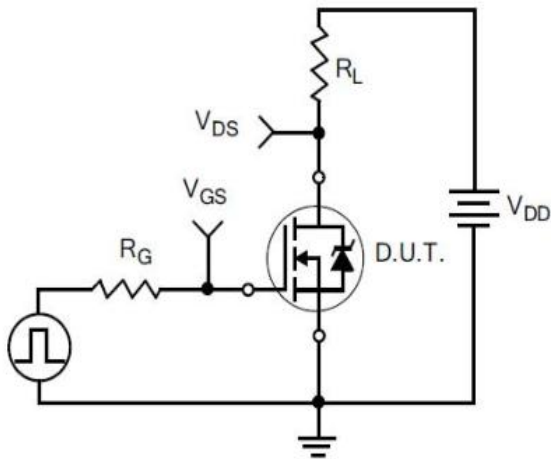

3) Resistive Switching Test Circuit

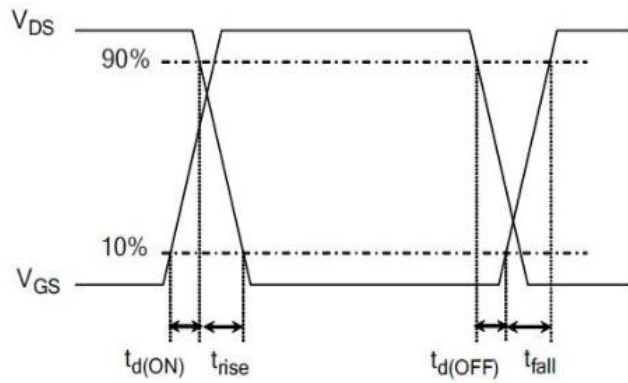

4) Resistive Switching Waveforms

6 Typical Test Circuit and Waveform(continues)

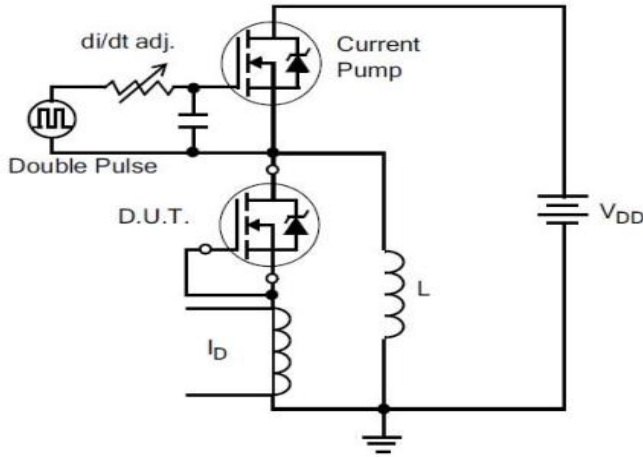

5) Diode Reverse Recovery Test Circuit

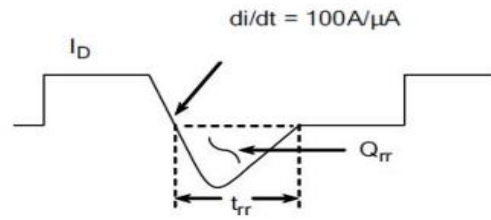

6) Diode Reverse Recovery Waveform

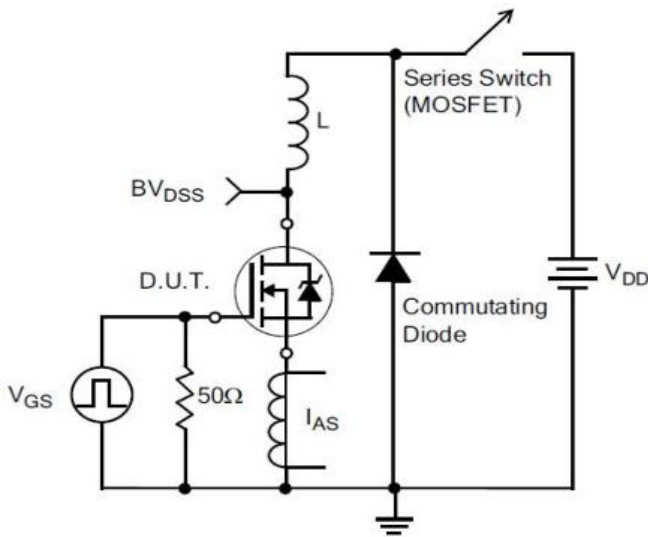

7) . Unclamped Inductive Switching Test Circuit

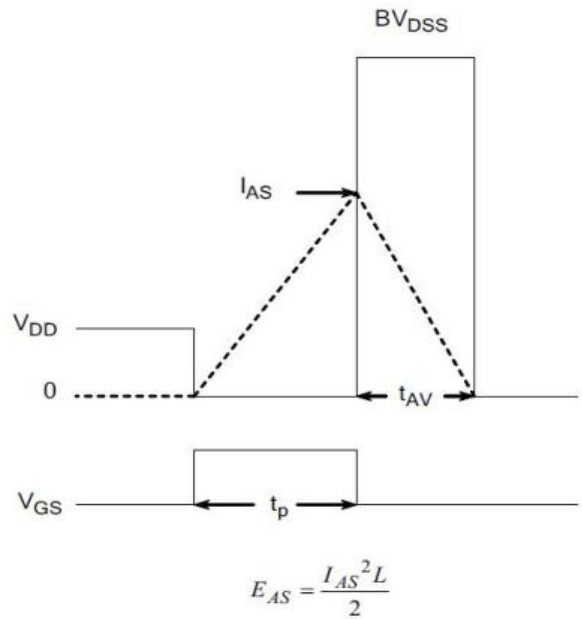

8) Unclamped Inductive Switching Waveforms

7 Product Names Rules

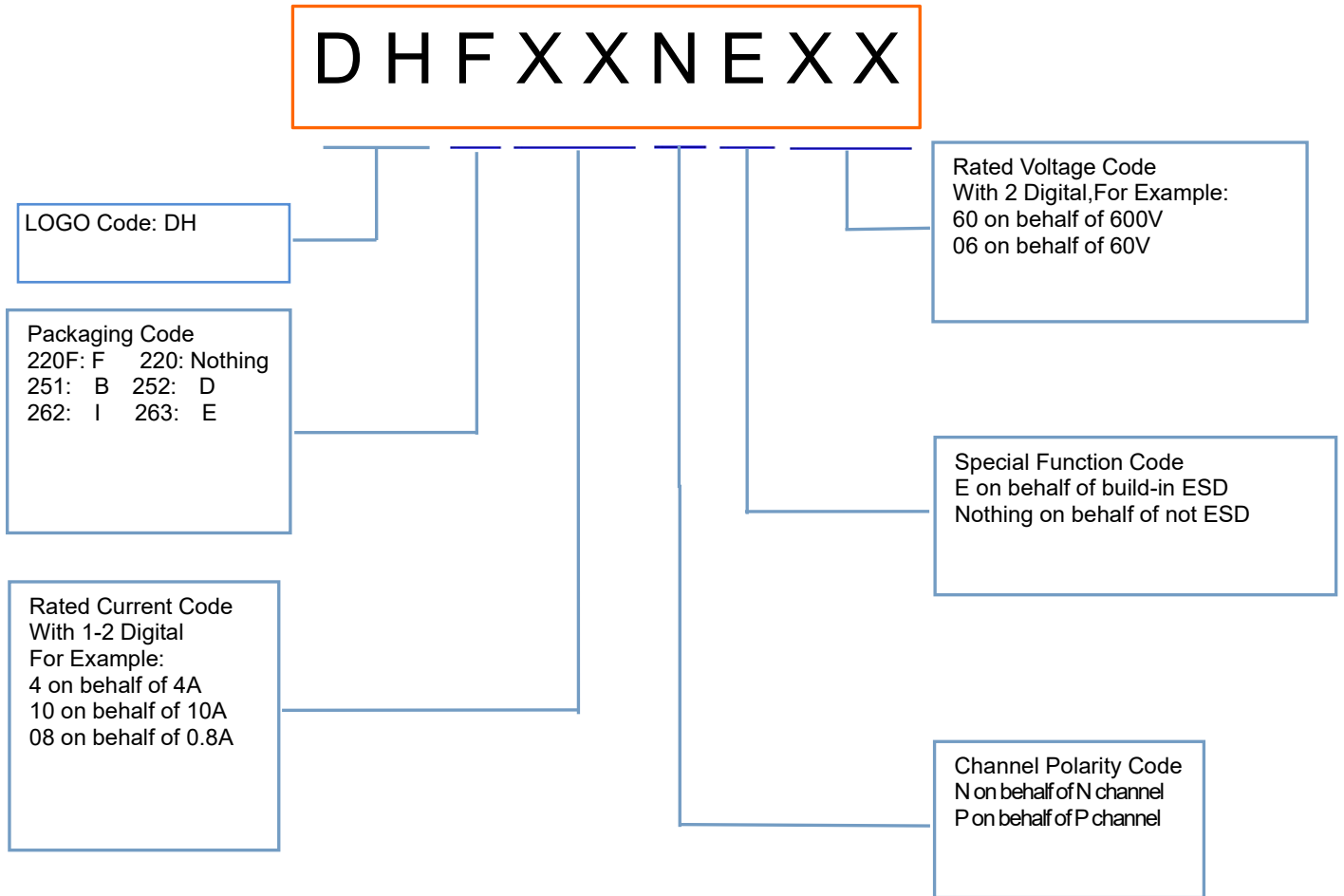

8 Product Specifications and Packaging Models

Product Model	Package Type	Mark Name	RoHS	Package	Quantity
DH3205A	TO-220	DH3205A	Pb-free	Tube	1000/box
DHF3205A	TO-220F	DHF3205A	Pb-free	Tube	1000/box
DHB3205A	TO-251	DHB3205A	Pb-free	Tube	3000/box
DHD3205A	TO-252	DHD3205A	Pb-free	Tape & Reel	2500/box
DHI3205A	TO-262	DHI3205A	Pb-free	Tube	1000/box
DHE3205A	TO-263	DHE3205A	Pb-free	Tape & Reel	800/box

9 Dimensions

TO-251B PACKAGE OUTLINE DIMENSIONS

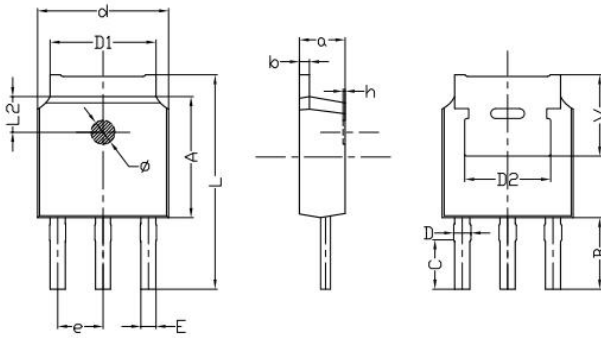

Symbol	Dimensions In Millimeters		Dimensions In Inches	
	min.	max.	min.	max.
a	2.20	2.40	0.087	0.0946
b	0.46	0.58	0.018	0.023
C	2.45	2.65	0.097	0.104
D	0.80	0.90	0.032	0.035
d	6.30	6.70	0.248	0.264
D1	5.00	5.50	0.197	0.217
D2	TYP 4.83		TYP 0.190	
A	5.80	6.20	0.228	0.244
e	2.19	2.39	0.086	0.094
L	10.40	11.00	0.4098	0.4334
B	3.50	3.70	0.1379	0.1458
L2	1.5	1.8	0.059	0.071
Φ	1.10	1.30	0.0433	0.0512
h	0.00	0.30	0.000	0.012
V	5.25	5.85	0.207	0.230
E	0.60	0.80	0.0236	0.0315

TO-252B PACKAGE OUTLINE DIMENSIONS

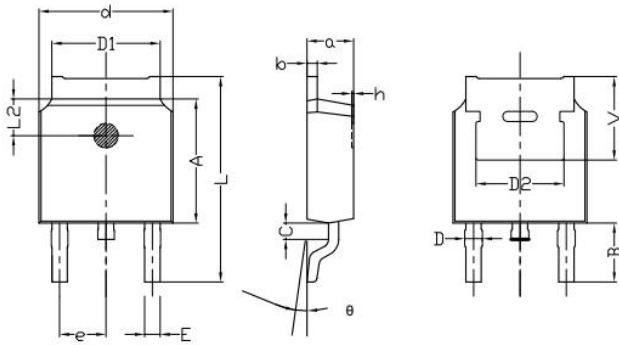

Symbol	Dimensions In Millimeters		Dimensions In Inches	
	min.	max.	min.	max.
a	2.20	2.40	0.087	0.095
b	0.46	0.58	0.018	0.023
c	0.70	0.90	0.028	0.035
D	0.80	1.00	0.032	0.039
d	6.30	6.70	0.248	0.264
D1	5.00	5.50	0.197	0.217
D2	TYP 4.83		TYP 0.190	
A	5.80	6.20	0.228	0.244
e	2.19	2.39	0.086	0.094
L	9.40	10.40	0.370	0.409
B	2.6	3.2	0.102	0.126
L2	1.5	1.8	0.059	0.071
θ	0	8	0	8
h	0	0.3	0	0.012
V	5.25	5.85	0.207	0.230
E	0.6	0.8	0.024	0.032

9 Dimensions(continues)

TO-220C PACKAGE OUTLINE DIMENSIONS

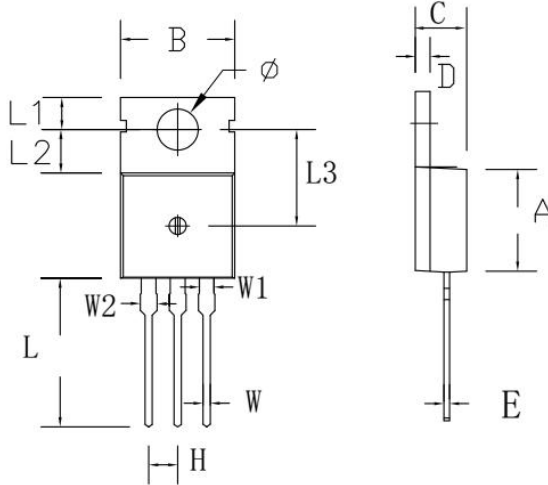

Symbol	Dimensions In Millimeters		Dimensions In Inches	
	min.	max.	min.	max.
A	8.80	9.30	0.346	0.366
B	9.70	10.30	0.382	0.406
C	4.25	4.75	0.167	0.187
D	1.20	1.45	0.047	0.057
E	0.40	0.60	0.016	0.024
H	2.54 TYP		0.100 TYP	
W	0.60	0.95	0.024	0.037
W1	1.05	1.45	0.041	0.057
W2	1.20	1.60	0.047	0.063
L	12.60	13.40	0.496	0.528
L1	2.45	2.95	0.096	0.116
L2	3.45	3.95	0.136	0.156
L3	8.15	8.65	0.321	0.341
Φ	3.50	3.90	0.138	0.154

TO-220F PACKAGE OUTLINE DIMENSIONS

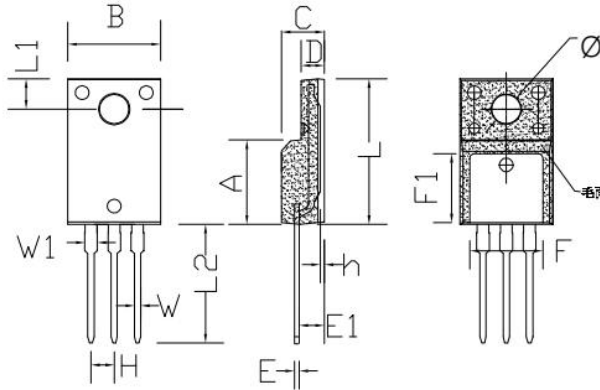

Symbol	Dimensions In Millimeters		Dimensions In Inches	
	min.	max.	min.	max.
A	8.80	9.30	0.346	0.366
B	10.00	10.50	0.394	0.413
C	4.30	4.90	0.169	0.193
D	2.30	2.70	0.091	0.106
L	15.55	16.15	0.612	0.636
h	0.40	0.60	0.016	0.024
L1	3.15	3.55	0.124	0.140
L2	12.65	13.35	0.498	0.526
W	0.70	0.90	0.028	0.035
W1	1.15	1.55	0.045	0.061
H	2.54 TYP		0.100 TYP	
E	0.48	0.53	0.019	0.021
Φ	2.90	3.40	0.114	0.134
E1	2.40	2.90	0.094	0.114
F	7.75	8.25	0.305	0.325
F1	7.35	7.85	0.289	0.309

9 Dimensions(continues)

TO-262 PACKAGE OUTLINE DIMENSIONS

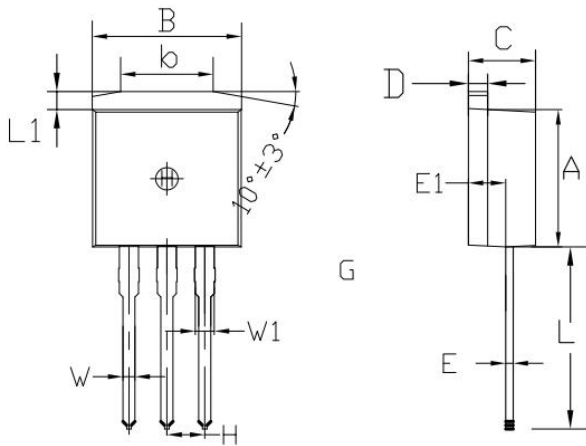

Symbol	Dimensions In Millimeters		Dimensions In Inches	
	min.	max.	min.	max.
A	8.80	9.30	0.346	0.366
B	9.70	10.30	0.382	0.406
C	4.25	4.75	0.167	0.187
D	1.20	1.45	0.047	0.057
E	0.40	0.60	0.016	0.024
L	12.25	13.75	0.482	0.541
L1	1.15	1.45	0.045	0.057
E1	2.4	2.6	0.0945	0.1024
W	0.80	0.82	0.0315	0.034
W1	1.20	1.30	0.047	0.051
H	2.54 TYP		0.200 TYP	
b	5.50	6.50	0.216	0.256

TO-263 PACKAGE OUTLINE DIMENSIONS

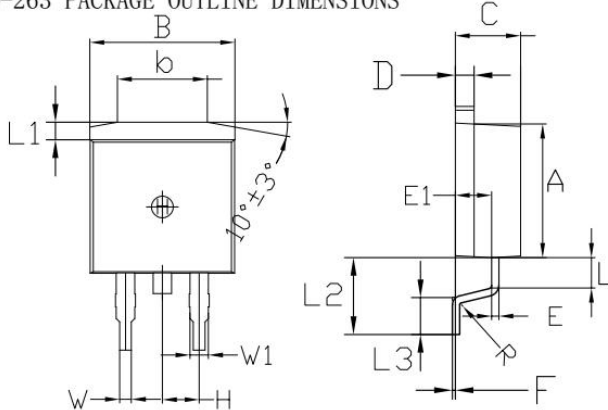

Symbol	Dimensions In Millimeters		Dimensions In Inches	
	min.	max.	min.	max.
A	8.80	9.30	0.346	0.366
B	9.70	10.30	0.382	0.406
C	4.25	4.75	0.167	0.187
D	1.20	1.45	0.047	0.057
E	0.40	0.60	0.016	0.024
L	1.90	2.30	0.075	0.091
L1	1.15	1.45	0.045	0.057
R	0.24	0.26	0.0095	0.0102
W	0.80	0.82	0.0315	0.0323
W1	1.20	1.30	0.047	0.051
H	2.54 TYP		0.200 TYP	
b	5.50	6.50	0.216	0.256
E1	2.4	2.6	0.0946	0.1024
L2	5.20	5.80	0.205	0.228
L3	2.20	3.20	0.087	0.126
F	0.03	0.23	0.0012	0.0091

10 Attentions

- Jiangsu Donghai Semiconductor Technology CO.,LTD. reserves the right to change the specification without prior notice! The customer should obtain the latest version of the information before making the order and verify that the information is complete and up to date.
- It is the responsibility of the purchaser for any failure or failure of any semiconductor product under certain conditions. It is the responsibility of the purchaser to comply with safety standards and to take safety measures in the system design and machine manufacturing of Donghai products in order to avoid potential risk of failure. Injury or property damage.
- Product promotion is endless, our company will be dedicated to provide customers with better products.

11 Appendix

Revision history:

Date	REV.	Description	Page
2019.12.13	1.0	Original	