

-40A -60V P-channel Enhancement Mode Power MOSFET

1 Description

These P-channel enhancement mode power mosfets used advanced trench technology design, provided excellent Rdson and low gate charge. Which accords with the RoHS standard.

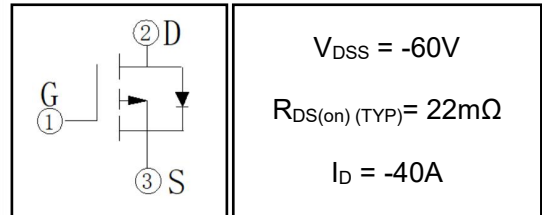

2 Features

- Low on resistance
- Low gate charge
- Fast switching
- Low reverse transfer capacitances
- 100% single pulse avalanche energy test
- 100% ΔV_{DS} test

3 Applications

- Power switching applications
- DC-DC converters
- Full bridge control

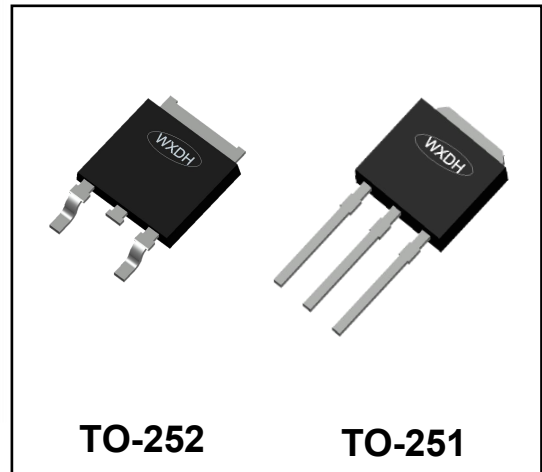

4 Electrical Characteristics

4.1 Absolute Maximum Ratings (Tc=25°C, unless otherwise noted)

Parameter		Symbol	Rating	Units
Drian-to-Source Voltage		V_{DSS}	-60	V
Gate-to-Source Voltage		V_{GSS}	± 20	V
Continuous Drain Current	$T_C=25^\circ C$	I_D	-40	A
	$T_C=100^\circ C$		-28	A
Pulsed Drain Current ⁽¹⁾		I_{DM}	-160	A
Single Pulse Avalanche Energy ⁽⁴⁾		E_{AS}	256	mJ
Power Dissipation	$T_a=25^\circ C$	P_{tot}	1.74	W
	$T_C=25^\circ C$	P_{tot}	158	W
Junction Temperature Range		T_j	-55~175	$^\circ C$
Storage Temperature Range		T_{stg}	-55~175	$^\circ C$

4.2 Thermal Characteristics

Parameter	Symbol	Rating	Units
Thermal Resistance, Junction to Case-sink	R_{thJC}	0.95	$^\circ C/W$
Thermal Resistance, Junction to Ambient	R_{thJA}	86.3	$^\circ C/W$

4.3 Electrical Characteristics (T_c=25°C, unless otherwise noted)

Parameter	Symbol	Test Condition	Value			Units
			Min	Typ	Max	
Off Characteristics						
Drain-to-Source Breakdown Voltage	BV _{DSS}	I _D =-250μA, V _{GS} =0V	-60	-66	--	V
Drain-to-Source Leakage Current	I _{DSS}	V _{DS} =-48V, V _{GS} =0V, T _C =25°C	--	--	-1	μA
		V _{DS} =-48V, V _{GS} =0V, T _C =125°C	--	--	-10	μA
Gate-to-Source Leakage Current	I _{GSS}	V _{GS} =±20V, V _{DS} =0V	--	--	±100	nA
On Characteristics						
Gate Threshold Voltage	V _{GS(th)}	V _{DS} =V _{GS} , I _D =-250μA	-1.2	-1.5	-2	V
Drain-to-Source on-state Resistance	R _{DS(on)}	V _{GS} =-10V, I _D =-20A	--	22	30	mΩ
		V _{GS} =-4.5V, I _D =-20A	--	27	37	
Forward Transfer Conductance	g _{fs}	V _{DS} =-50V, I _D =-7.8A	--	20	--	S
Dynamic Characteristics						
Input Capacitance	C _{iss}	V _{GS} =0V, V _{DS} =-30V, f=1.0MHz	--	3193	--	pF
Output Capacitance	C _{oss}		--	180	--	
Reverse Transfer Capacitance	C _{rss}		--	150	--	
Switching Characteristics						
Turn-on Delay Time	t _{d(on)}	V _{GS} =-10V, V _{DS} =-30V RD=3Ω, RG=1.5Ω	--	14	--	nS
Turn-on Rise Time	t _r		--	6.4	--	
Turn-off Delay Time	t _{d(off)}		--	88	--	
Turn-off Fall Time	t _f		--	13	--	
Total Gate Charge	Q _g	I _D =-20A, V _{DD} =-30V, V _{GS} =-10V	--	57	--	nC
Gate-to-Source Charge	Q _{gs}		--	9.3	--	
Gate-to-Drain("Miller") Charge	Q _{gd}		--	10.5	--	
Drain-Source Diode Characteristics						
Diode Forward Voltage ⁽³⁾	V _{SD}	V _{GS} =0V, I _S =-7.8A	--	-0.8	-1.2	V
Diode Forward Current	I _S		--	--	-40	A

Notes:

- 1: Repetitive rating, pulse width limited by maximum junction temperature.
- 2: Surface mounted on FR4 Board, t_s≤10sec.
- 3: Pulse width ≤ 300μs, duty cycle ≤ 2%.
- 4: L=0.5mH, V_{DD}=-30V, V_G=-10V, Start T_J=25°C.

5 Typical characteristics diagrams

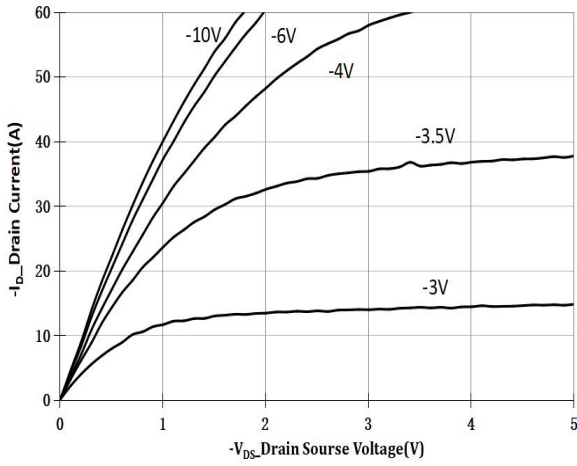

Fig 1 Output Characteristics

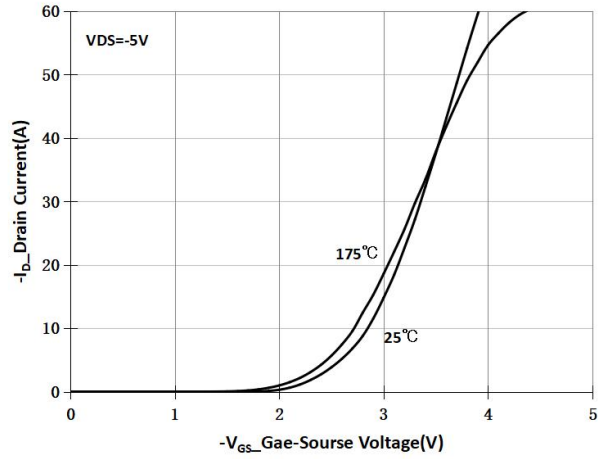

Fig 2 Transfer Characteristics

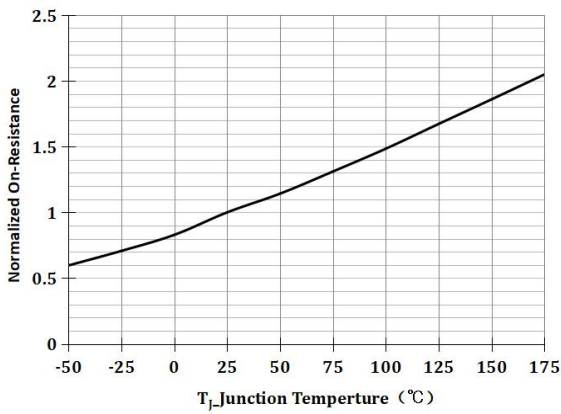

Fig 3 RDSON vs Junction Temperature

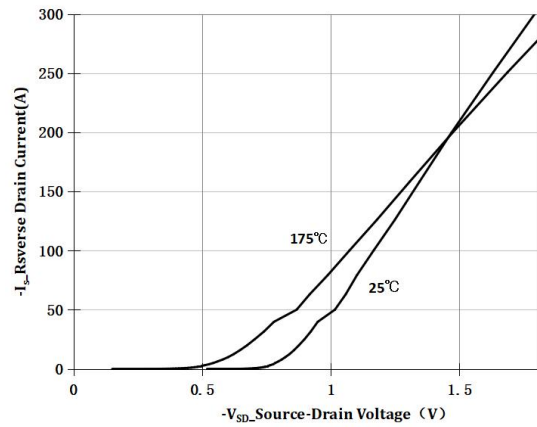

Fig 4 V_{SD} Source-Drain Diode forward

5 Typical characteristics diagrams(continues)

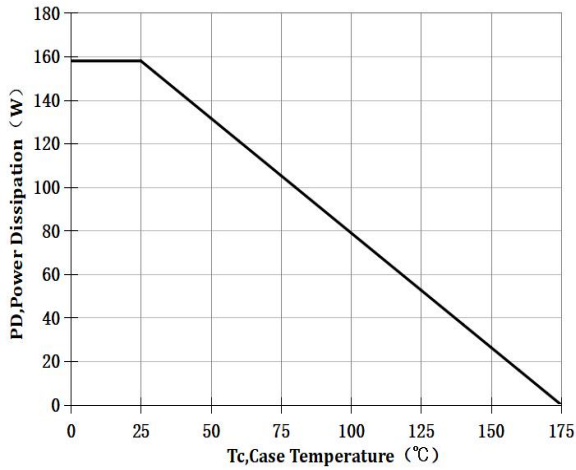

Fig 5 Power De-rating

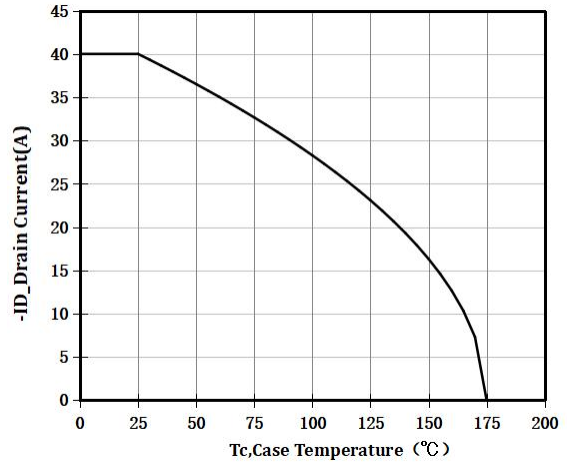

Fig 6 ID Current De-rating

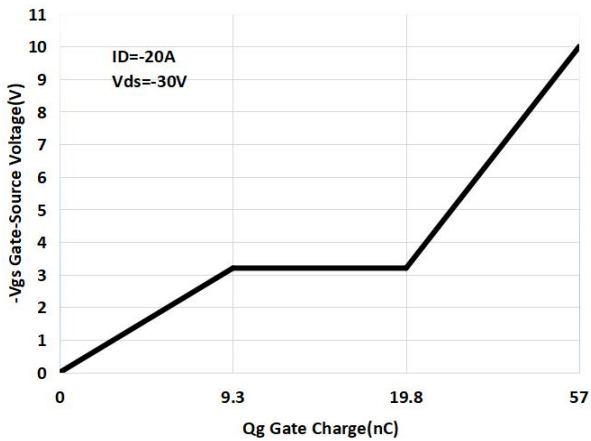

Fig 7 Gate Charge Figure

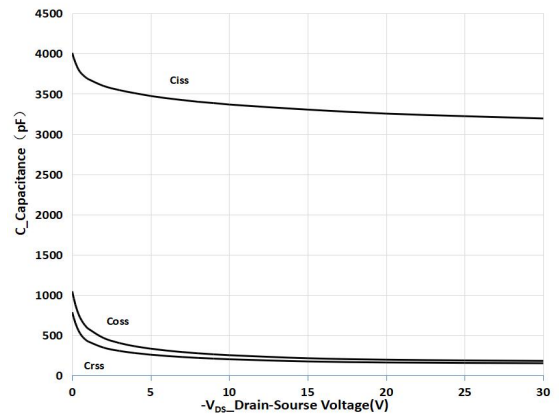

Fig 8 Capacitance vs Vds

5 Typical characteristics diagrams(continues)

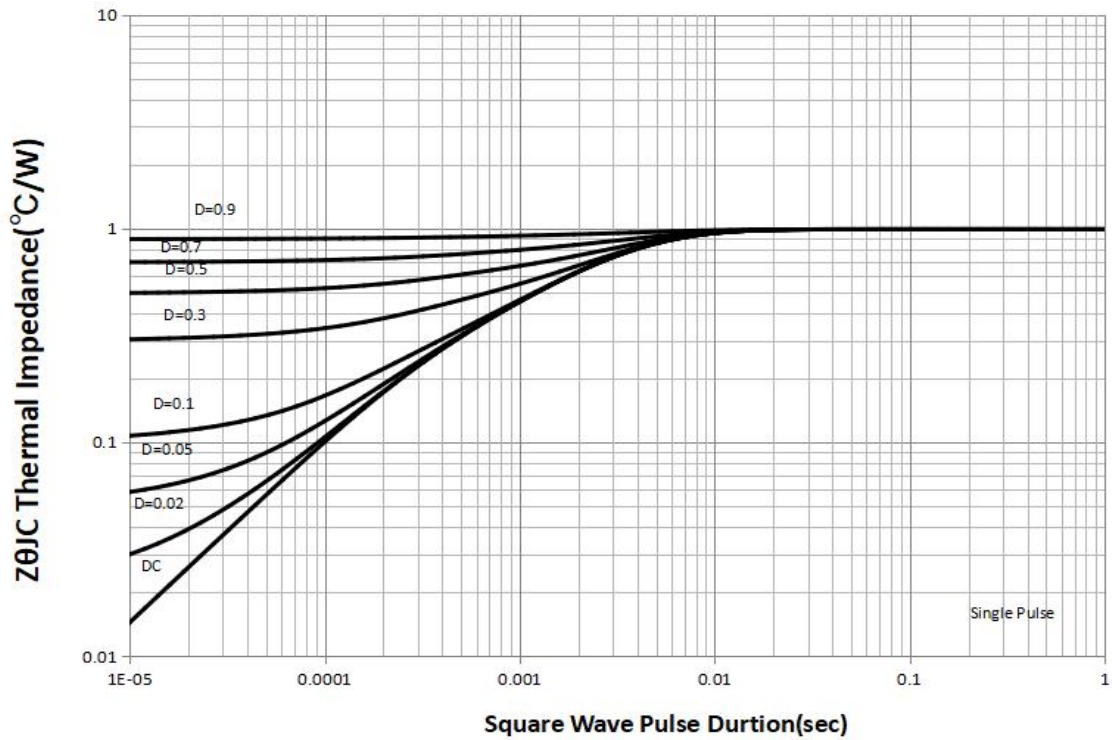

Fig 9 Normalized Maximum Transient Thermal Impedance

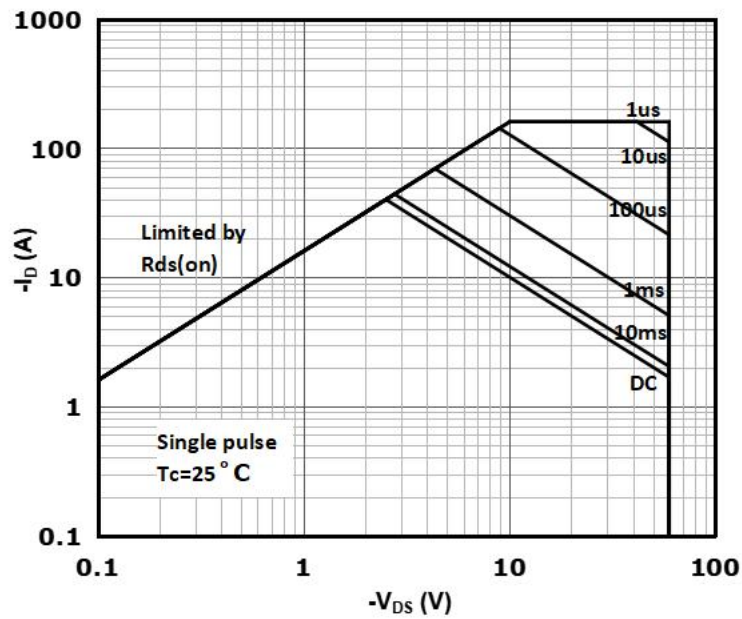
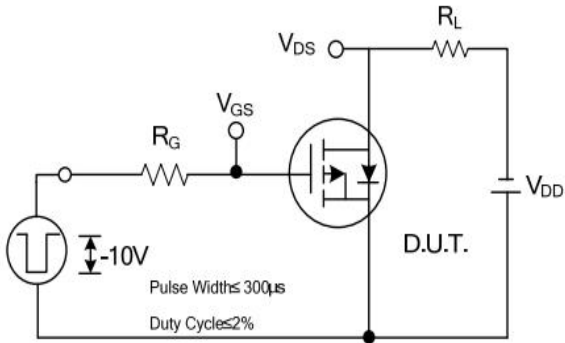
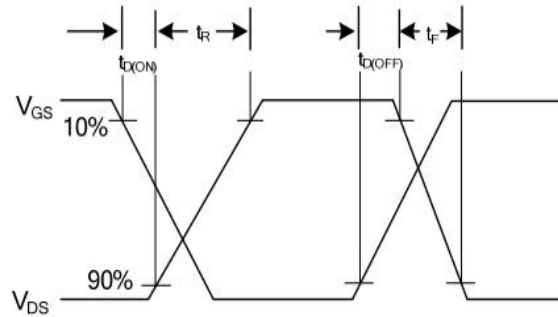

Fig 10 Safe Operation Area

6 Typical Test Circuit and Waveform



Switching Test Circuit



Switching Waveforms

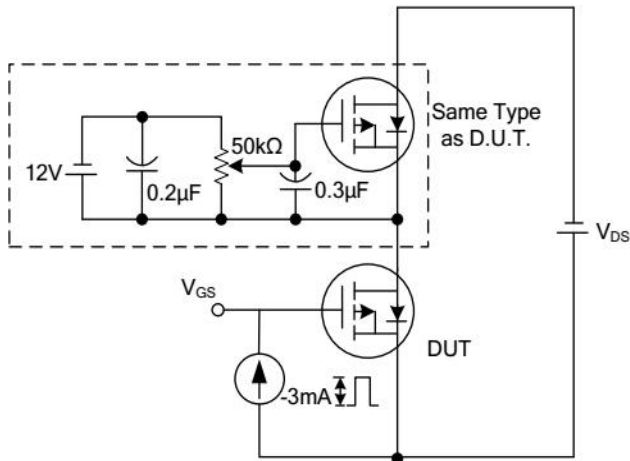

Gate Charge Test Circuit

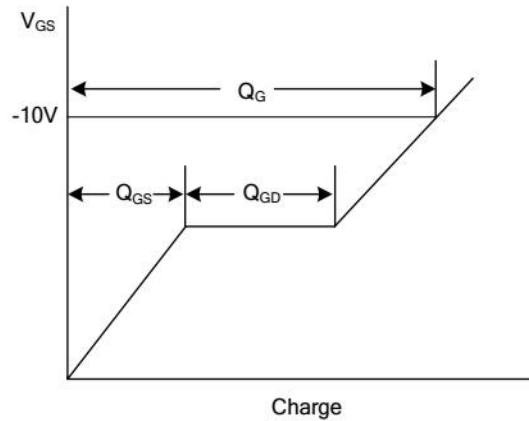

Gate Charge Waveform

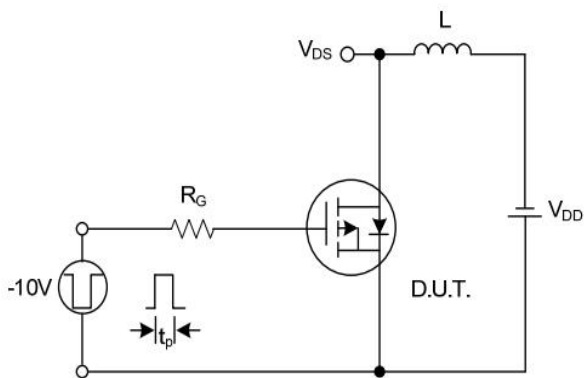

Unclamped Inductive Switching Test Circuit

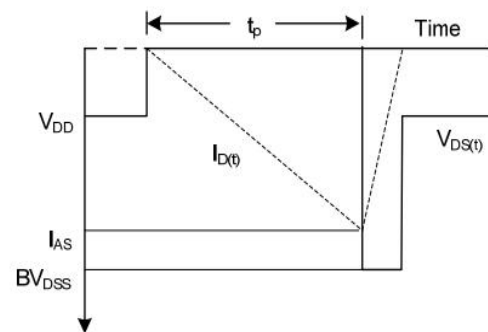

Unclamped Inductive Switching Waveforms

7 Dimensions

TO-252B PACKAGE OUTLINE DIMENSIONS

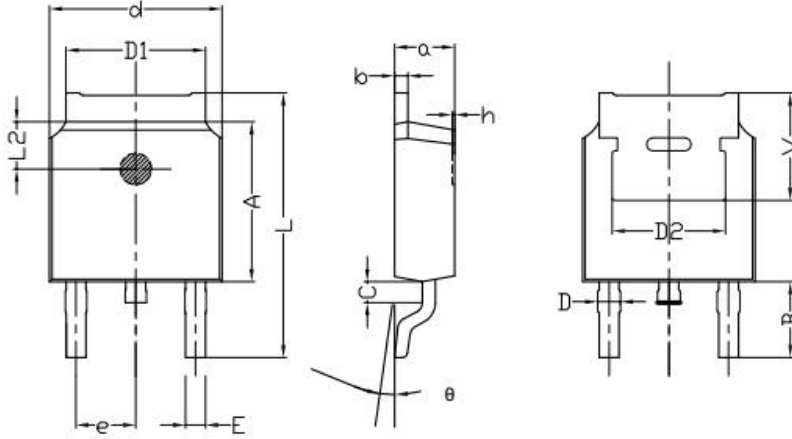

Symbol	Dimensions In Millimeters		Dimensions In Inches	
	min.	max.	min.	max.
a	2.20	2.40	0.087	0.095
b	0.46	0.58	0.018	0.023
c	0.70	0.90	0.028	0.035
D	0.80	1.00	0.032	0.039
d	6.30	6.70	0.248	0.264
D1	5.00	5.50	0.197	0.217
D2	TYP 4.83		TYP 0.190	
A	5.80	6.20	0.228	0.244
e	2.19	2.39	0.086	0.094
L	9.40	10.40	0.370	0.409
B	2.6	3.2	0.102	0.126
L2	1.5	1.8	0.059	0.071
θ	0	8	0	8
h	0	0.3	0	0.012
V	5.25	5.85	0.207	0.230
E	0.6	0.8	0.024	0.032

7 Dimensions(continues)

TO-251B PACKAGE OUTLINE DIMENSIONS

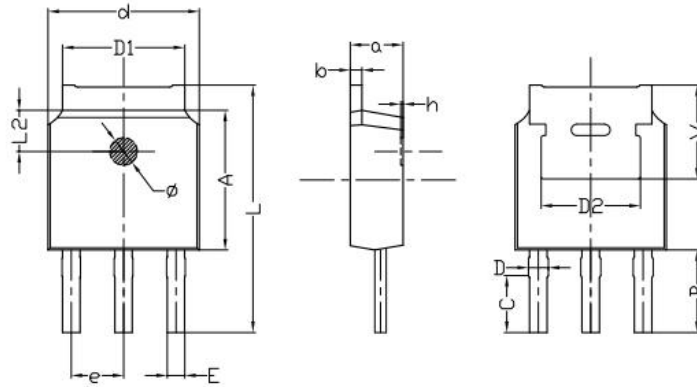

Symbol	Dimensions In Millimeters		Dimensions In Inches	
	min.	max.	min.	max.
a	2.20	2.40	0.087	0.0946
b	0.46	0.58	0.018	0.023
C	2.45	2.65	0.097	0.104
D	0.80	0.90	0.032	0.035
d	6.30	6.70	0.248	0.264
D1	5.00	5.50	0.197	0.217
D2	TYP 4.83		TYP 0.190	
A	5.80	6.20	0.228	0.244
e	2.19	2.39	0.086	0.094
L	10.40	11.00	0.4098	0.4334
B	3.50	3.70	0.1379	0.1458
L2	1.5	1.8	0.059	0.071
Φ	1.10	1.30	0.0433	0.0512
h	0.00	0.30	0.000	0.012
V	5.25	5.85	0.207	0.230
E	0.60	0.80	0.0236	0.0315

8 Product Specifications and Packaging Models

Product Model	Package Type	Mark Name	RoHS	Package	Quantity
DH400P06LD	TO-252	DH400P06LD	Pb-free	Tape & Reel	2500/box
DH400P06LB	TO-251	DH400P06LB	Pb-free	Tube	3000/box

9 Attentions

- Jiangsu Donghai Semiconductor Technology CO.,LTD. reserves the right to change the specification without prior notice! The customer should obtain the latest version of the information before making the order and verify that the information is complete and up to date.
- It is the responsibility of the purchaser for any failure or failure of any semiconductor product under certain conditions. It is the responsibility of the purchaser to comply with safety standards and to take safety measures in the system design and machine manufacturing of Donghai products in order to avoid potential risk of failure. Injury or property damage.
- Product promotion is endless, our company will be dedicated to provide customers with better products.

10 Appendix

Revision history:

Date	REV.	Description	Page
2022.07.01	1.0	Original	9
2023.06.06	2.0	Modified	9