

## 40A 30V N-channel Enhancement Mode Power MOSFET

### 1 Description

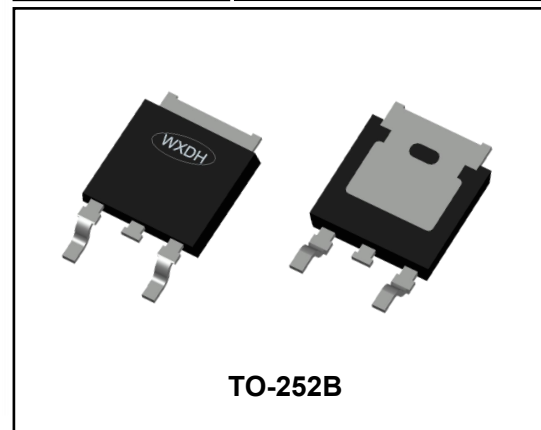
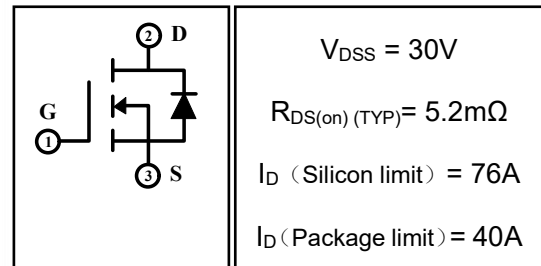
These N-channel enhancement mode power mosfets used advanced trench technology design, provided excellent  $R_{DS(on)}$  and low gate charge. Which accords with the RoHS standard.

### 2 Features

- Low on resistance
- Low gate charge
- Fast switching
- Low reverse transfer capacitances
- 100% single pulse avalanche energy test
- 100%  $\Delta V_{DS}$  test

### 3 Applications

- Power switching applications
- Inverter management system
- Electric tools
- Automotive electronics



### 4 Electrical Characteristics

#### 4.1 Absolute Maximum Ratings (Tc=25°C, unless otherwise noted)

Parameter		Symbol	Rating	Units
Drain-to-Source Voltage		$V_{DSS}$	30	V
Gate-to-Source Voltage		$V_{GSS}$	$\pm 20$	V
Continuous Drain Current	$T_C = 25^\circ C$ (Silicon limit)	$I_D$	76	A
	$T_C = 25^\circ C$ (Package limit)		40	A
	$T_C = 100^\circ C$ (Package limit)		40	A
Pulsed Drain Current <sup>(1)</sup>		$I_{DM}$	160	A
Single Pulse Avalanche Energy <sup>(4)</sup>		$E_{AS}$	169	mJ
Power Dissipation	$T_a = 25^\circ C$	$P_{tot}$	1.9	W
	$T_C = 25^\circ C$	$P_{tot}$	65	W
Junction Temperature Range		$T_j$	-55 ~ 175	$^\circ C$
Storage Temperature Range		$T_{stg}$	-55 ~ 175	$^\circ C$

#### 4.2 Thermal Characteristics

Parameter	Symbol	Rating	Units
Thermal Resistance, Junction to Case-sink	$R_{thJC}$	2.3	$^\circ C/W$
Thermal Resistance, Junction to Ambient	$R_{thJA}$	78	$^\circ C/W$

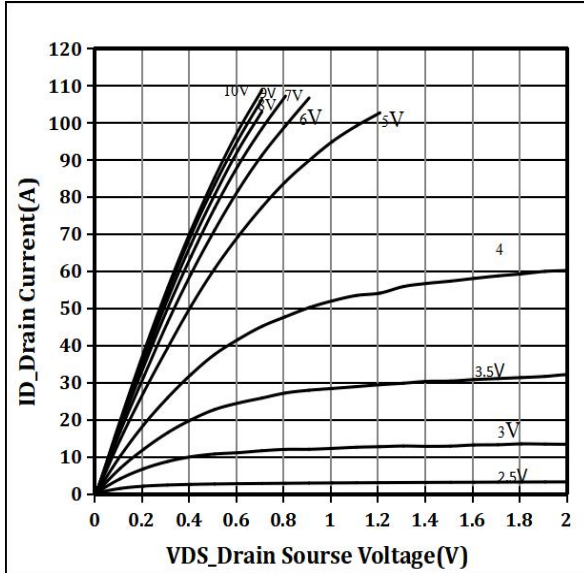
**4.3 Electrical Characteristics** (Tc=25°C, unless otherwise noted)

Parameter	Symbol	Test Condition	Value			Units
			Min	Typ	Max	
<b>Off Characteristics</b>						
Drain-to-Source Breakdown Voltage	BV <sub>DSS</sub>	I <sub>D</sub> =250μA, V <sub>GS</sub> =0V	30	--	--	V
Drain-to-Source Leakage Current	I <sub>DSS</sub>	V <sub>DS</sub> =30V, V <sub>GS</sub> =0V, T <sub>C</sub> =25°C	--	--	1	μA
		V <sub>DS</sub> =30V, V <sub>GS</sub> =0V, T <sub>C</sub> =125°C	--	--	100	μA
Gate-to-Source Leakage Current	I <sub>GSS</sub>	V <sub>GS</sub> =±20V, V <sub>DS</sub> =0V	--	--	±100	nA
<b>On Characteristics</b>						
Gate Threshold Voltage	V <sub>GS(th)</sub>	V <sub>DS</sub> =V <sub>GS</sub> , I <sub>D</sub> =250μA	1	1.5	2	V
Drain-to-Source on-state Resistance	R <sub>DS(on)</sub>	V <sub>GS</sub> =10V, I <sub>D</sub> =30A	--	5.2	6.2	mΩ
		V <sub>GS</sub> =4.5V, I <sub>D</sub> =20A	--	8.7	10.5	mΩ
<b>Dynamic Characteristics</b>						
Input Capacitance	C <sub>iss</sub>	V <sub>GS</sub> =0V, V <sub>DS</sub> =15V, f=1.0MHz	--	1483	--	pF
Output Capacitance	C <sub>oss</sub>		--	204	--	
Reverse Transfer Capacitance	C <sub>rss</sub>		--	191	--	
Gate Resistance	R <sub>G</sub>	V <sub>DD</sub> =0V, V <sub>GS</sub> =0V, F=1MHz	--	1.2	--	Ω
<b>Switching Characteristics</b>						
Turn-on Delay Time	t <sub>d(on)</sub>	I <sub>D</sub> =40A, V <sub>DD</sub> =15V, V <sub>GS</sub> =10V, R <sub>GEN</sub> =2Ω	--	6.3	--	nS
Turn-on Rise Time	t <sub>r</sub>		--	10.2	--	
Turn-off Delay Time	t <sub>d(off)</sub>		--	26.3	--	
Turn-off Fall Time	t <sub>f</sub>		--	8.2	--	
Total Gate Charge	Q <sub>g</sub>	I <sub>D</sub> =40A, V <sub>DD</sub> =15V, V <sub>GS</sub> =10V	--	31	--	nC
Gate-to-Source Charge	Q <sub>gs</sub>		--	7.0	--	
Gate-to-Drain("Miller") Charge	Q <sub>gd</sub>		--	5.6	--	
<b>Drain-Source Diode Characteristics</b>						
Diode Forward Voltage <sup>(3)</sup>	V <sub>SD</sub>	V <sub>GS</sub> =0V, I <sub>S</sub> =30A	--	--	1.3	V
Diode Forward Current	I <sub>S</sub>		--	--	40	A
Reverse Recovery Time	t <sub>rr</sub>	T <sub>J</sub> =25°C, I <sub>F</sub> =20A, di/dt=100A/μs, V <sub>DS</sub> =24V	--	18.9	--	nS
Reverse Recovery charge	Q <sub>rr</sub>		--	10.8	--	nC

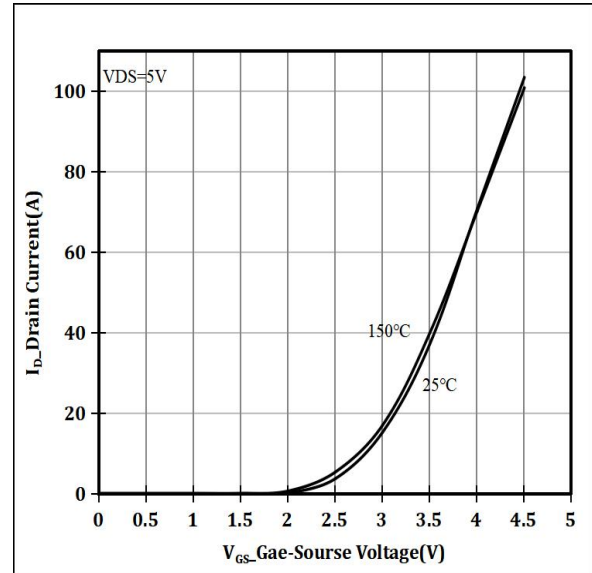
**Notes:**

- 1: Repetitive rating, pulse width limited by maximum junction temperature.
- 2: Surface mounted on FR4 Board, t<sub>≤</sub>10sec.
- 3: Pulse width ≤ 300μs, duty cycle ≤ 2%.
- 4: EAS condition: L=0.5mH, I<sub>D</sub>=18A, V<sub>DD</sub>=25V, V<sub>GATE</sub>=30V, Start T<sub>J</sub>=25°C.

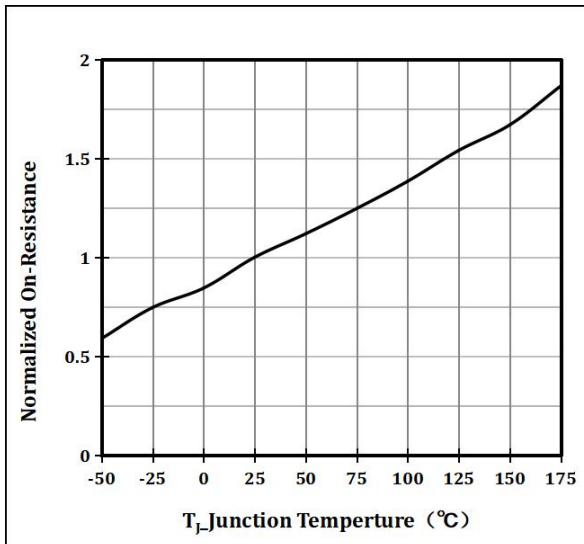
**5 Typical characteristics diagrams**



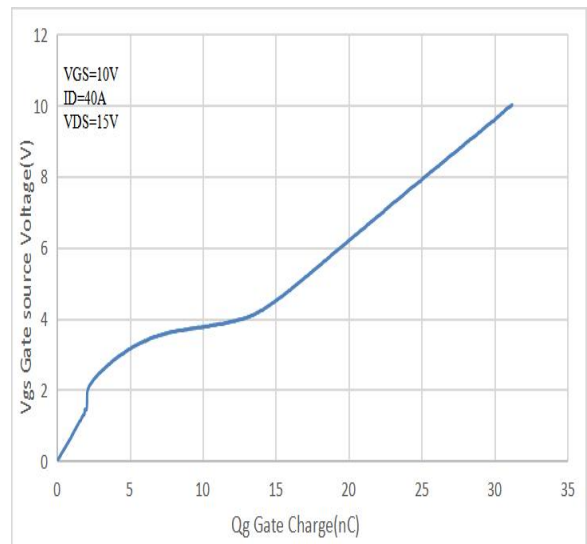
**Figure 1 Output Characteristics**



**Figure 2 Transfer Characteristics**

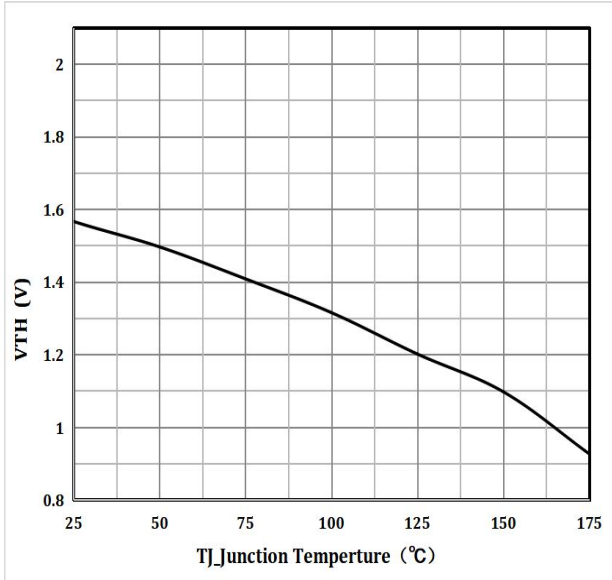


**Figure 3  $R_{DS(ON)}$  - Junction Temperature**

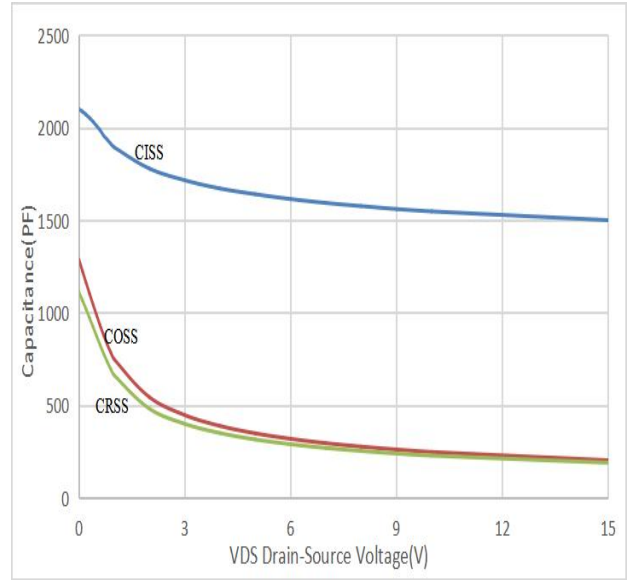


**Figure 4 Gate Charge**

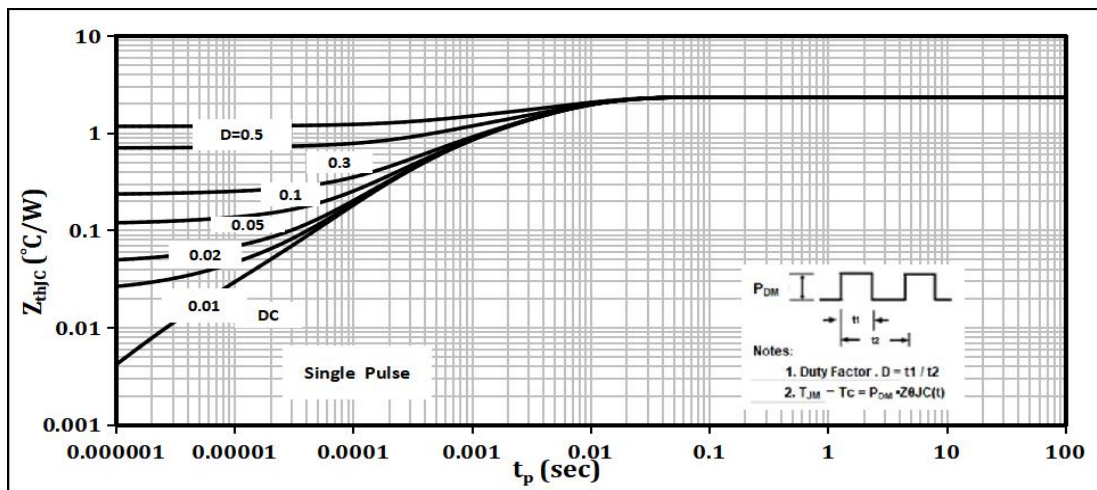
**5 Typical characteristics diagrams(continues)**



**Figure 5 Threshold vs Temperature**

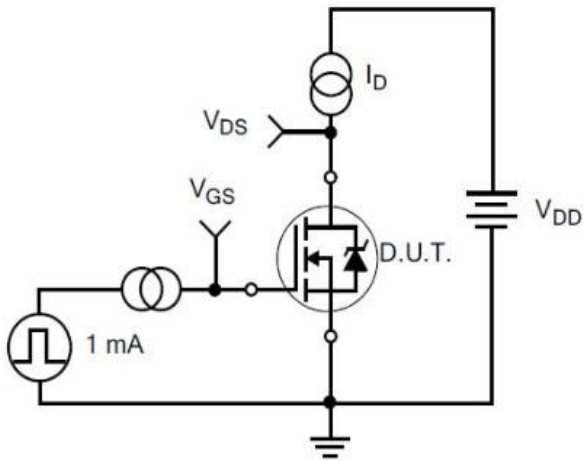


**Figure 6 Capacitance Vs V<sub>DS</sub>**

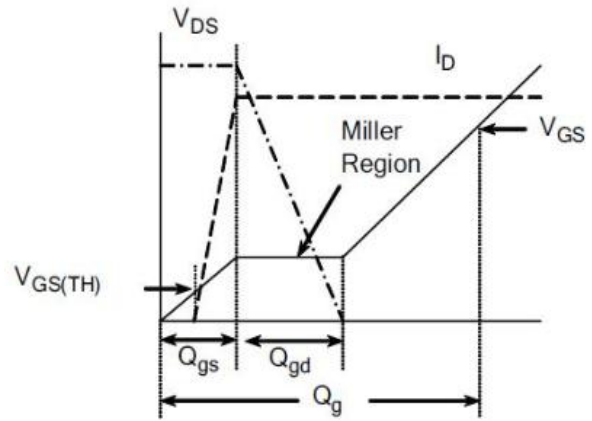


**Figure 7 Normalized Maximum Transient Thermal Impedance**

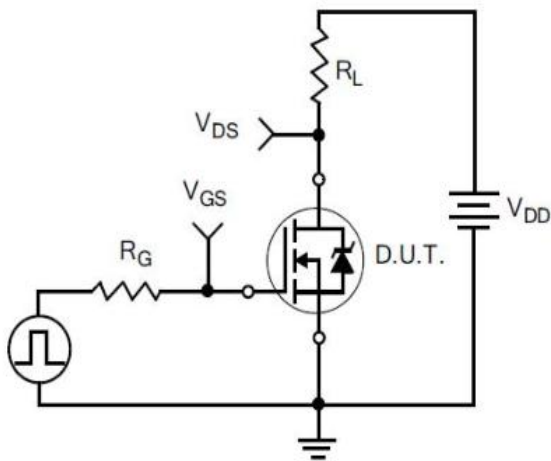
**6 Typical Test Circuit and Waveform**



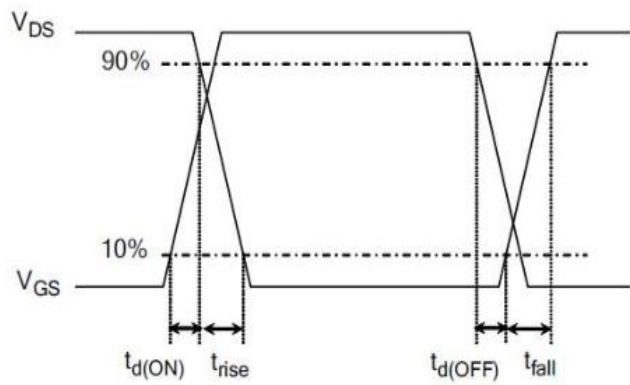
1) Gate Charge Test Circuit



2) . Gate Charge Waveform

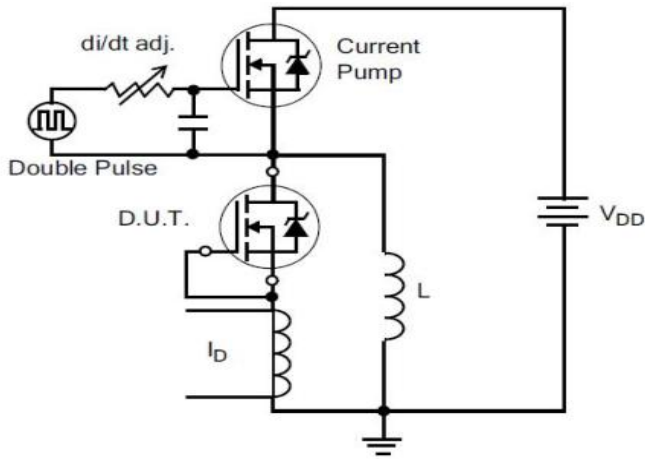


3) Resistive Switching Test Circuit

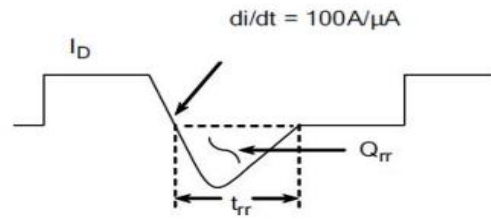


4) Resistive Switching Waveforms

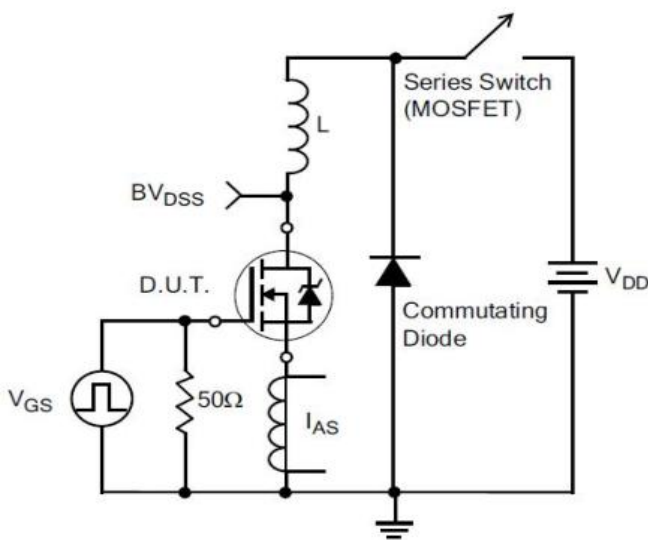
**6 Typical Test Circuit and Waveform(continues)**



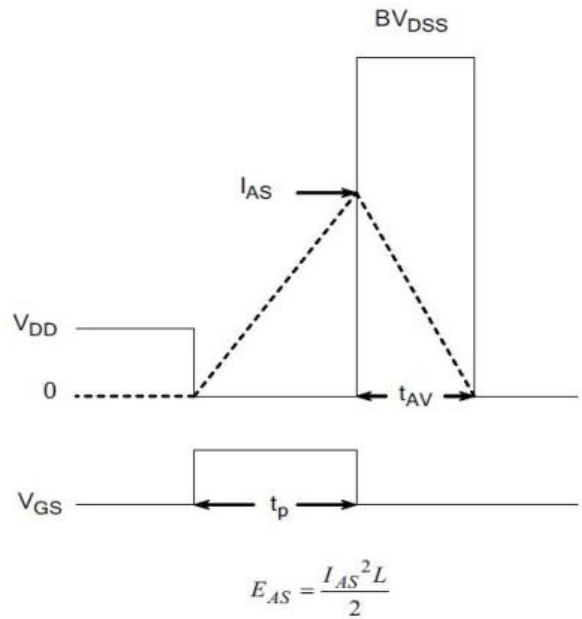
5) Diode Reverse Recovery Test Circuit



6) Diode Reverse Recovery Waveform



7) . Unclamped Inductive Switching Test Circuit



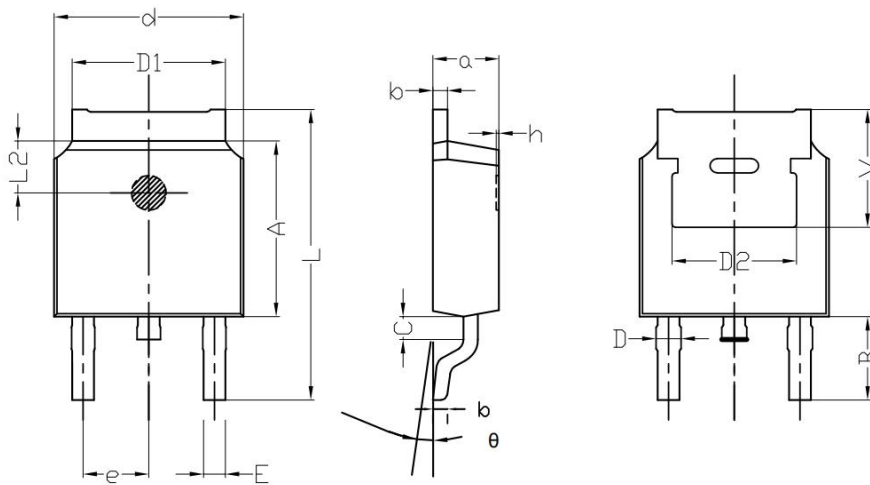
8) Unclamped Inductive Switching Waveforms

7 Product Specifications and Packaging Models

Product Model	Package Type	Mark Name	RoHS	Package	Quantity
DHD80N03	TO-252	DHD80N03	Pb-free	Tape & Reel	2500/box

8 Dimensions

TO-252B PACKAGE OUTLINE DIMENSIONS



Symbol	Dimensions In Millimeters		Dimensions In Inches	
	min.	max.	min.	max.
a	2.20	2.40	0.087	0.095
b	0.46	0.58	0.018	0.023
c	0.70	0.90	0.028	0.035
D	0.80	1.00	0.032	0.039
d	6.30	6.70	0.248	0.264
D1	5.00	5.50	0.197	0.217
D2	TYP 4.83		TYP 0.190	
A	5.80	6.20	0.228	0.244
e	2.19	2.39	0.086	0.094
L	9.40	10.40	0.370	0.409
B	2.6	3.2	0.102	0.126
L2	1.5	1.8	0.059	0.071
θ	0	8	0	8
h	0	0.3	0	0.012
V	5.25	5.85	0.207	0.230
E	0.6	0.8	0.024	0.032

## 9 Attentions

- Jiangsu Donghai Semiconductor Technology CO.,LTD. reserves the right to change the specification without prior notice! The customer should obtain the latest version of the information before making the order and verify that the information is complete and up to date.
- It is the responsibility of the purchaser for any failure or failure of any semiconductor product under certain conditions. It is the responsibility of the purchaser to comply with safety standards and to take safety measures in the system design and machine manufacturing of Donghai products in order to avoid potential risk of failure. Injury or property damage.
- Product promotion is endless, our company will be dedicated to provide customers with better products.

## 10 Appendix

Revision history:

Date	REV.	Description	Page
2020.11.12	1.0	Original	9
2022.05.10	2.0	Modified Full page	9
2023.4.18	3.0	Modified Continuous Drain Current	9