

4.8A 650V N-channel Super Junction Power MOSFET

1 Description

These N-channel enhanced VDMOSFETs, is using advanced super junction technology and design to provide excellent $R_{DS(on)}$ with low gate charge. Which accords with the RoHS standard.

2 Features

- Fast switching
- Low on resistance
- Low gate charge
- Low reverse transfer capacitances
- 100% single pulse avalanche energy test
- 100% ΔV_{DS} test

3 Applications

- Switched mode power supplies(SMPS).
- TV power & LED Lighting Power
- AC to DC Converters
- Telecom

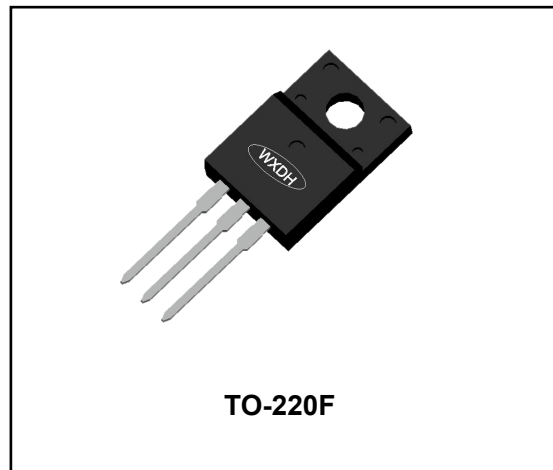
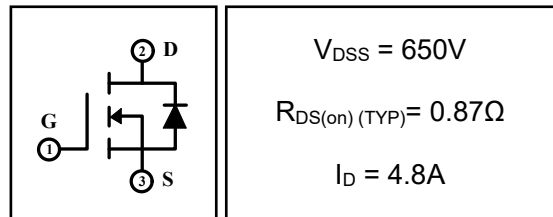

4 Electrical Characteristics

4.1 Absolute Maximum Rating ($T_C=25^\circ C$, unless otherwise noted)

Parameter	Symbol	Value	Units
Drain-to-Source Voltage	V_{DSS}	650	V
Gate-to-Source Voltage	V_{GSS}	± 20	V
Continuous Drain Current	I_D	$T_C=25^\circ C$	4.8
		$T_C=100^\circ C$	3.0
Pulsed Drain Current ⁽¹⁾	I_{DM}	14.4	A
Single Pulse Avalanche Energy ⁽⁴⁾	E_{AS}	43	mJ
Repetitive Avalanche Current ⁽⁴⁾	I_{AR}	1.0	A
Power Dissipation	P_{tot}	$T_a=25^\circ C$	2
		$T_C=25^\circ C$	25
Gate-Source ESD (HBM-C=100pF,R=1.5K Ω)	$V_{ESD(G-S)}$	2000	V
Isolation Voltage	V_{ISO}	2500	V
Junction Temperature Range	T_j	-55~150	$^\circ C$
Storage Temperature Range	T_{stg}	-55~150	$^\circ C$

4.2 Thermal Characteristics

Parameter	Symbol	Typ	Unit
Thermal Resistance, Junction to Case-sink	R_{thJC}	5	$^\circ C/W$
Thermal Resistance, Junction to Ambient	R_{thJA}	62.5	$^\circ C/W$

4.3 Electrical Characteristics (T_C=25°C, unless otherwise noted)

Parameter	Symbol	Test Condition	Value			Units
			Min	Typ	Max	
Off Characteristics						
Drain-to-Source Breakdown Voltage	BV _{DSS}	I _D =250μA, V _{GS} =0V	650	--	--	V
Drain-to-Source Leakage Current	I _{DSS}	V _{DS} =650V, V _{GS} =0V, T _C =25°C	--	--	1	μA
		V _{DS} =650V, V _{GS} =0V, T _C =150°C	--	--	100	μA
Gate-to-Source Leakage Current	I _{GSS}	V _{GS} =±20V	--	--	±1000	nA
On Characteristics						
Gate Threshold Voltage	V _{GS(th)}	V _{DS} =V _{GS} , I _D =250μA	2	--	4	V
Drain-to-Source on-state Resistance	R _{DS(on)}	V _{GS} =10V, I _D =1.3A	--	0.87	1.0	Ω
Dynamic Characteristics						
Input Capacitance	C _{iss}	V _{GS} =0V, V _{DS} =400V, f=1.0MHz	--	390	--	pF
Output Capacitance	C _{oss}		--	13	--	
Reverse Transfer Capacitance	C _{rss}		--	2.1	--	
Switching Characteristics						
Turn-on Delay Time	t _{d(on)}	I _D =1.8A, V _{DD} =325V, V _{GS} =10V, R _G =25Ω	--	20	--	ns
Turn-on Rise Time	t _r		--	18	--	
Turn-off Delay Time	t _{d(off)}		--	54	--	
Turn-off Fall Time	t _f		--	19	--	
Total Gate Charge	Q _g	I _D =1.8A, V _{DD} =520V, V _{GS} =10V	--	9.3	--	nC
Gate-to-Source Charge	Q _{gs}		--	1.8	--	
Gate-to-Drain("Miller") Charge	Q _{gd}		--	3.0	--	
Drain-Source Diode Characteristics						
Diode Forward Voltage ⁽³⁾	V _{FSD}	V _{GS} =0V, I _S =1.8A	--	--	1.2	V
Diode Forward Current	I _S		--	--	4.8	A
Reverse Recovery Time ⁽³⁾	t _{rr}	T _J =25°C, I _F =1.8A, dI _F /dt=100A/μs, V _R =400V	--	210	--	ns
Reverse Recovery Charge ⁽³⁾	Q _{rr}		--	1200	--	nC

Notes:

- 1: Repetitive rating, pulse width limited by maximum junction temperature.
- 2: Surface mounted on FR4 Board, t_s≤10sec.
- 3: Pulse width ≤ 300μs, duty cycle ≤ 2%.
- 4: L=10mH, I_D=2.95A, V_{DD}=50V, V_{GS}=10V, R_G=25Ω, V_{GATE}=650V, Start T_J=25°C.

5 Typical characteristics diagrams

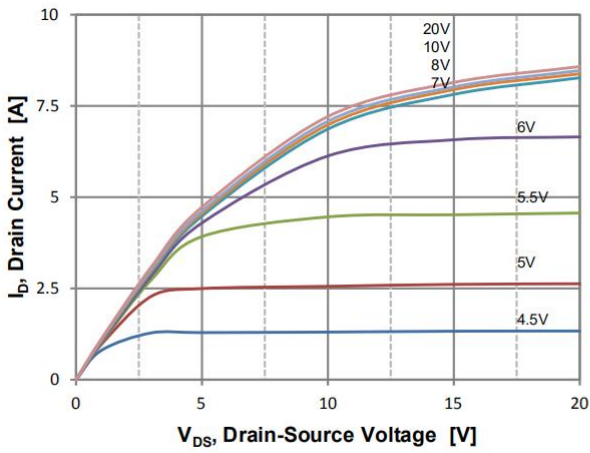

Figure 1. On Region Characteristics

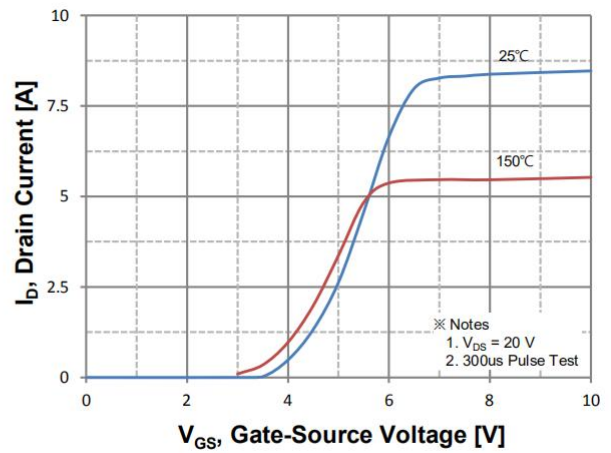

Figure 2. Transfer Characteristics

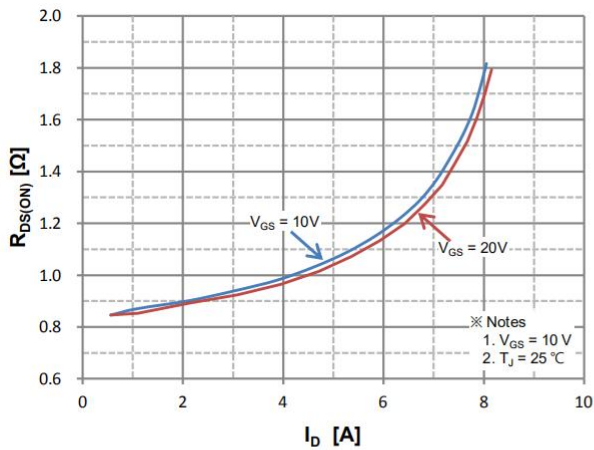

Figure 3. On Resistance Variation vs Drain Current and Gate Voltage

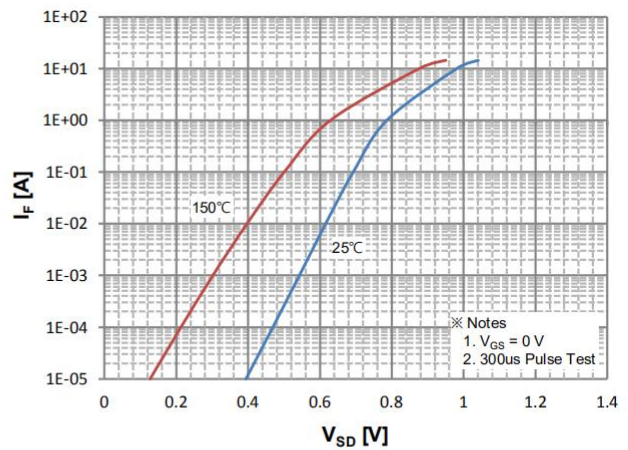

Figure 4. Body Diode Forward Voltage Variation with Source Current and Temperature

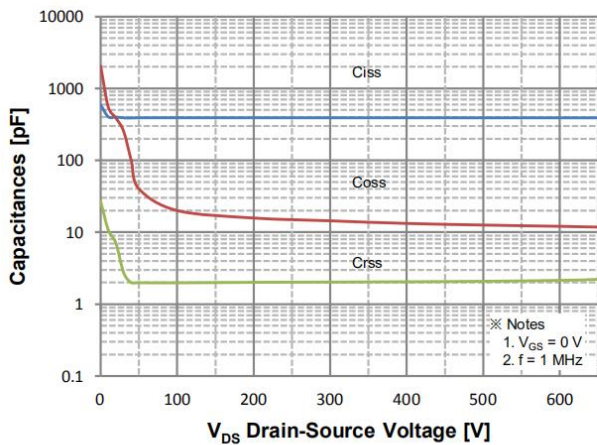

Figure 5. Capacitance Characteristics

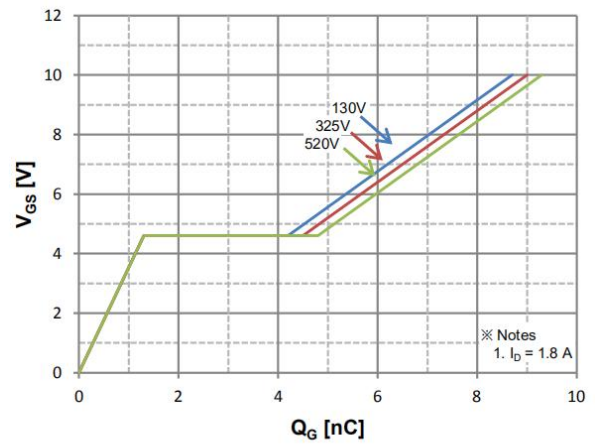

Figure 6. Gate Charge Characteristics

5 Typical characteristics diagrams(continues)

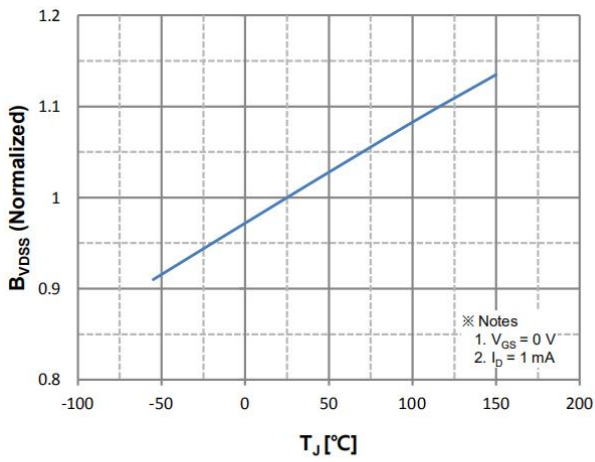

Figure 7. Breakdown Voltage Variation vs. Temperature

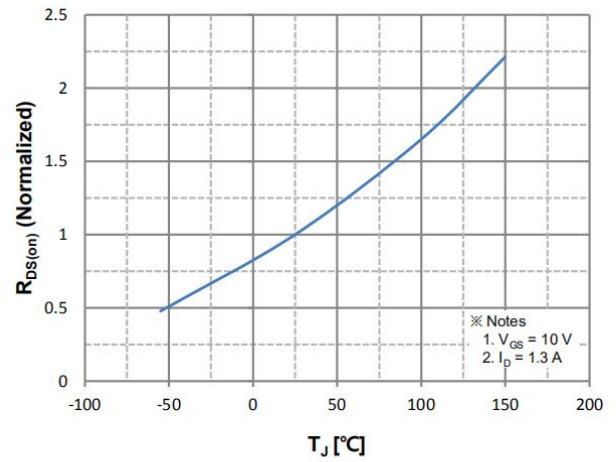

Figure 8. On-Resistance Variation vs. Temperature

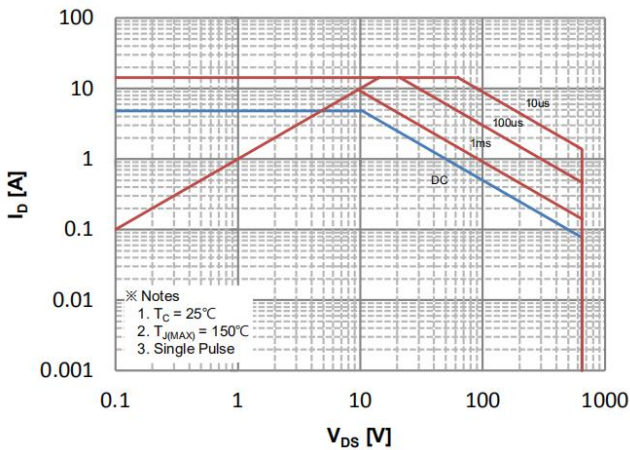

Figure 9. Maximum Safe Operating Area

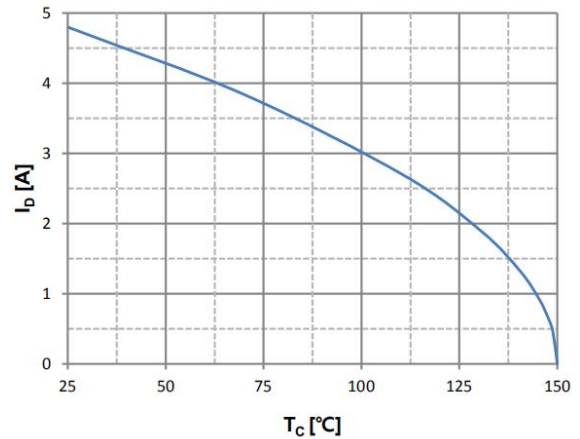

Figure 10. Maximum Drain Current vs. Case Temperature

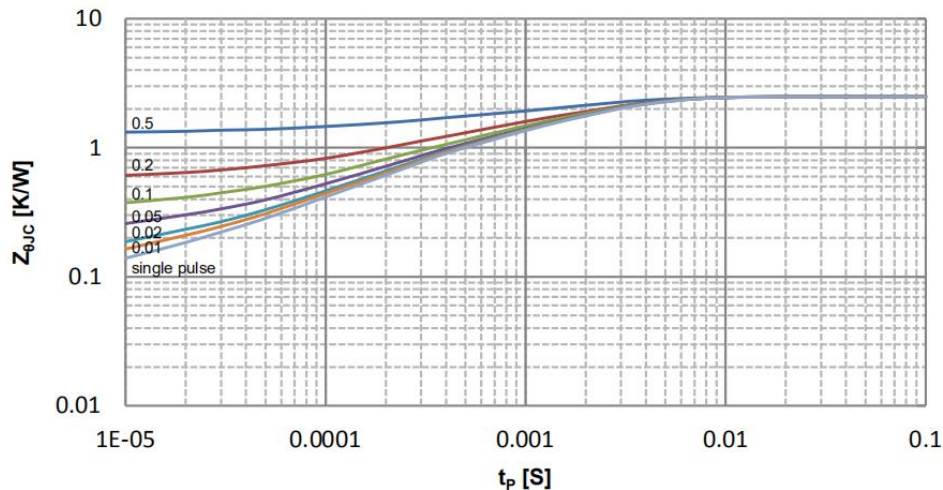
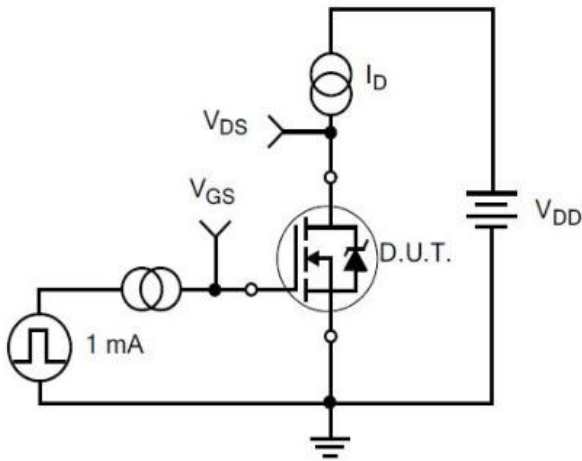
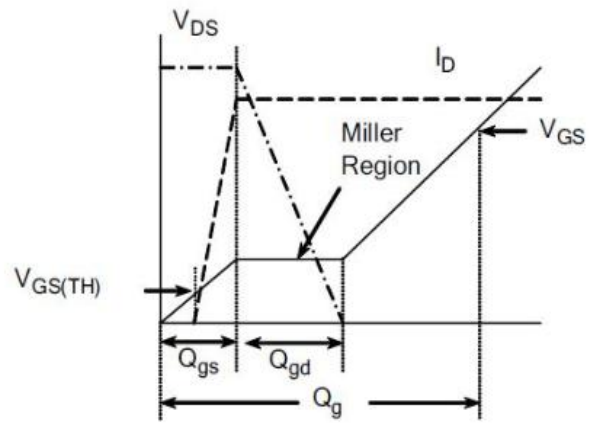

Figure 11. Transient Thermal Response Curve

6 Typical Test Circuit and Waveform



1) Gate Charge Test Circuit



2) . Gate Charge Waveform

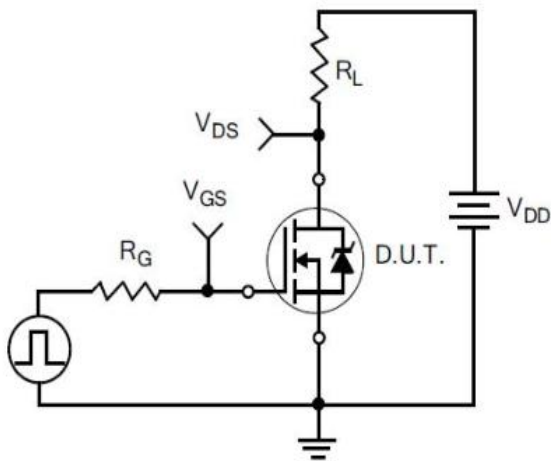

3) Resistive Switching Test Circuit

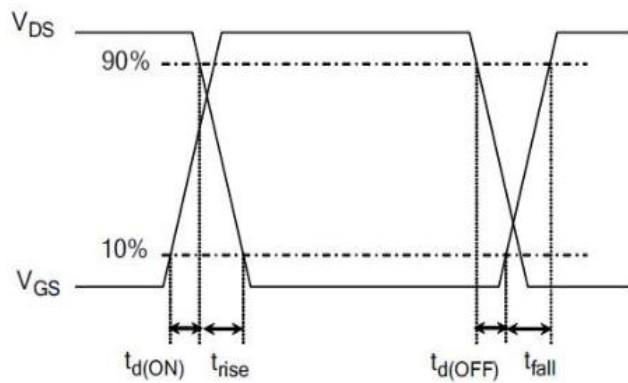

4) Resistive Switching Waveforms

6 Typical Test Circuit and Waveform(continues)

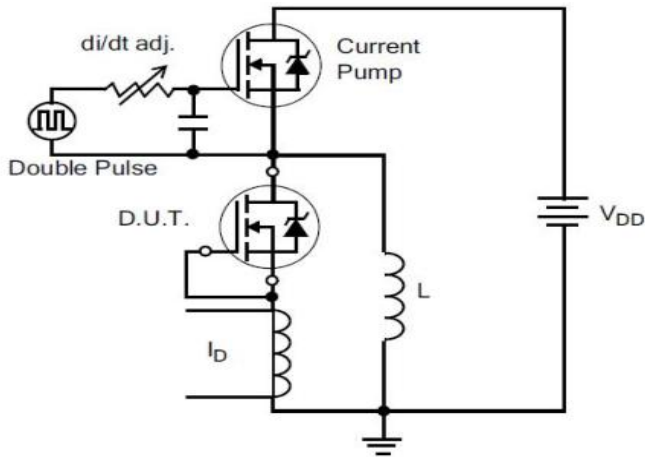

5) Diode Reverse Recovery Test Circuit

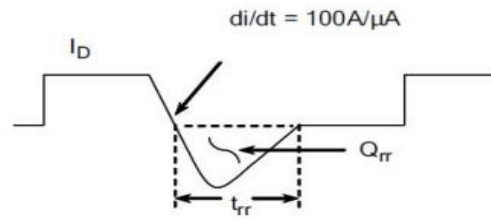

6) Diode Reverse Recovery Waveform

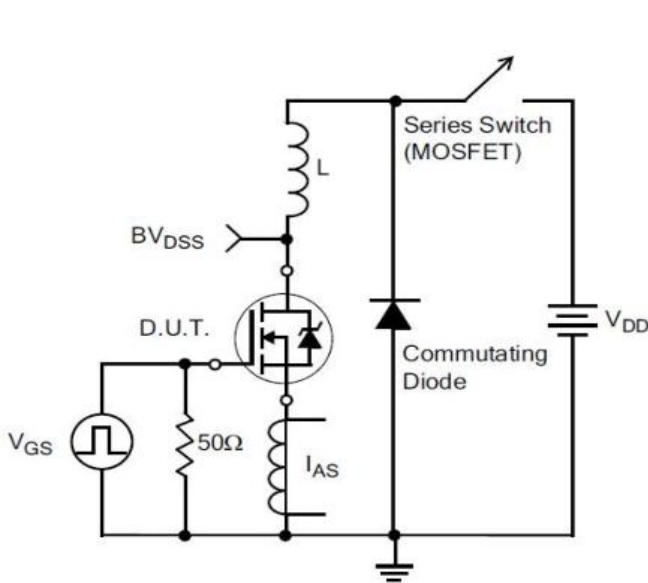

7) . Unclamped Inductive Switching Test Circuit

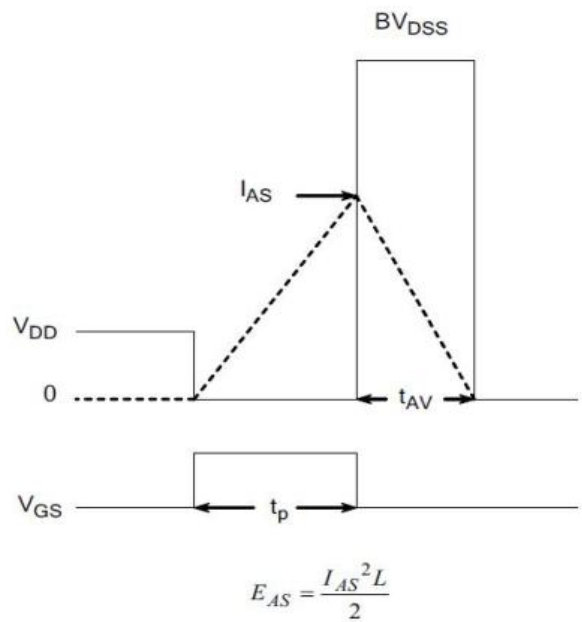

8) Unclamped Inductive Switching Waveforms

7 Product Specifications and Packaging Models

Product Model	Package Type	Mark Name	RoHS	Package	Quantity
DHFSJ5N65	TO-220F	DHFSJ5N65	Pb-free	Tube	1000/box

8 Dimensions

TO-220F PACKAGE OUTLINE

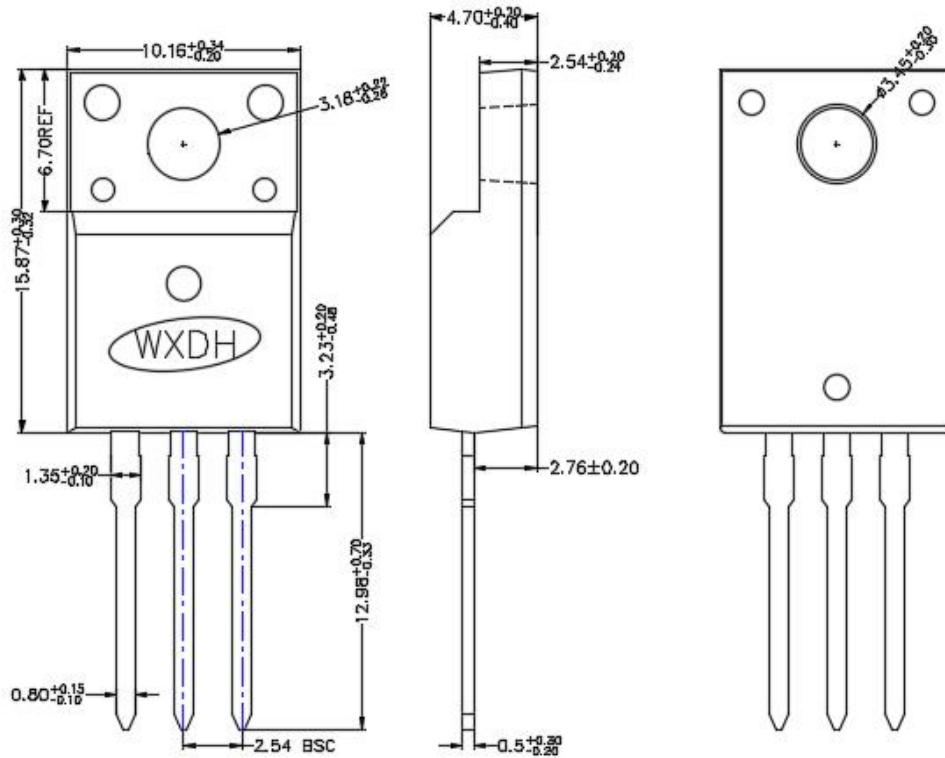

9 Attentions

- Jiangsu Donghai Semiconductor Technology CO.,LTD. reserves the right to change the specification without prior notice! The customer should obtain the latest version of the information before making the order and verify that the information is complete and up to date.
- It is the responsibility of the purchaser for any failure or failure of any semiconductor product under certain conditions. It is the responsibility of the purchaser to comply with safety standards and to take safety measures in the system design and machine manufacturing of Donghai products in order to avoid potential risk of failure. Injury or property damage.
- Product promotion is endless, our company will be dedicated to provide customers with better products.

10 Appendix

Revision history:

Date	REV.	Description	Page
2020.06.14	1.0	Original	7